

# INSTALLATION INSTRUCTIONS

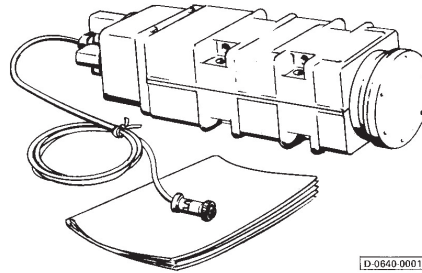

## DICKEY-john DjRVS II RADAR VELOCITY SENSOR



D-0640-0001

### DjRVS II SENSOR KIT

1. DjRVS II Sensor
2. Installation Instructions

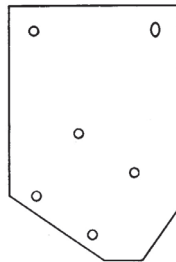

D-0640-0002

### PLATE MOUNTING BRACKET

Customer fabricated mounting plate (see dimensional drawing in Section A. PLATE MOUNTING BRACKET).

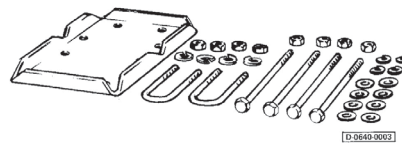

D-0640-0003

### DjRVS II MOUNTING BRACKET KIT

1. Mounting Bracket
2. U-Bolts 1 1/8" x 2" x 1/4 - 20 (2)
3. 1/4" Split Ring Lockwashers (8)
4. 1/4" Flatwashers (8)
5. 1/4 - 20 x 4" Bolts (4)
6. 1/4 - 20 Nuts (8)

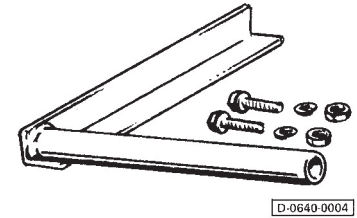

D-0640-0004

### DjRVS II "L" PIPE MOUNTING BRACKET KIT

1. "L" Pipe Mounting Bracket
2. 3/8 - 16 x 1 1/2" Bolts (2)
3. 3/8 Split Ring Lockwashers (2)
4. 3/8 Nuts (2)

The DjRVS II can be mounted several ways. The mounting kits are designed to give the user the option of fabricating his own mounting bracket, retrofitting to an existing DjRVS I "L" pipe mounting bracket, or using "L" shaped pipe mounting bracket kits purchased from DICKEY-john for new installations.

### SELECTING MOUNTING LOCATION

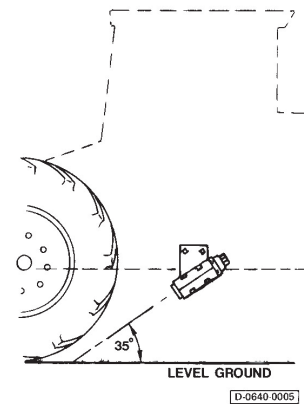

D-0640-0005

1. Refer to the above illustration and park the vehicle on level ground. This is necessary in order to install the sensor at the proper angle with respect to ground.

# INSTALLATION INSTRUCTIONS

2. The following list describes some of the precautions which should be followed when selecting a mounting location.

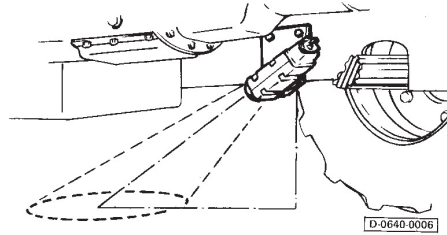

- a. The face of the sensor will have an unobstructed view of the ground.

The area that must remain unobstructed is cone shaped from the face of the sensor to the ground as shown. The pattern of the sensor signal on the ground is oval shaped due to the installation angle. The size of the oval pattern is dependent on the sensor height above ground. The following is the pattern size for the indicated height

<b>SENSOR HEIGHT</b>	<b>PATTERN SIZE (OVAL)</b>
18 inches	18.8 x 12.7 inches
24 inches	24.17 x 17.2 inches
48 inches	31.0 x 25.6 inches

- b. Fluids do not drip on sensor face area.
- c. The sensor is away from all heat sources.
- d. The sensor face or rear metal housing does not touch the vehicle.
- e. The sensor is protected from stubble and debris.

- f. It is recommended that the sensor be installed facing the rear of the vehicle. NOTE: There may be instances where the sensor will have to be oriented facing forward, but rear facing is preferred to offer more physical protection to the radar sensor.

- g. The sensor mounting location must have a minimal amount of vibration; excessive vibration may cause erroneous MPH readings with the vehicle stationary.

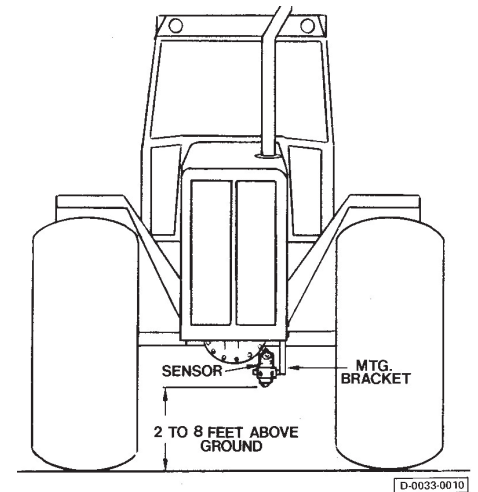

**NOTE:** Care must be exercised when selecting mounting heights of more than four feet. The sensor must have an unobstructed cone shaped view of the ground. If a vehicle tire, hose, or liquid line is within the cone shaped area, erroneous readings may result

# INSTALLATION INSTRUCTIONS

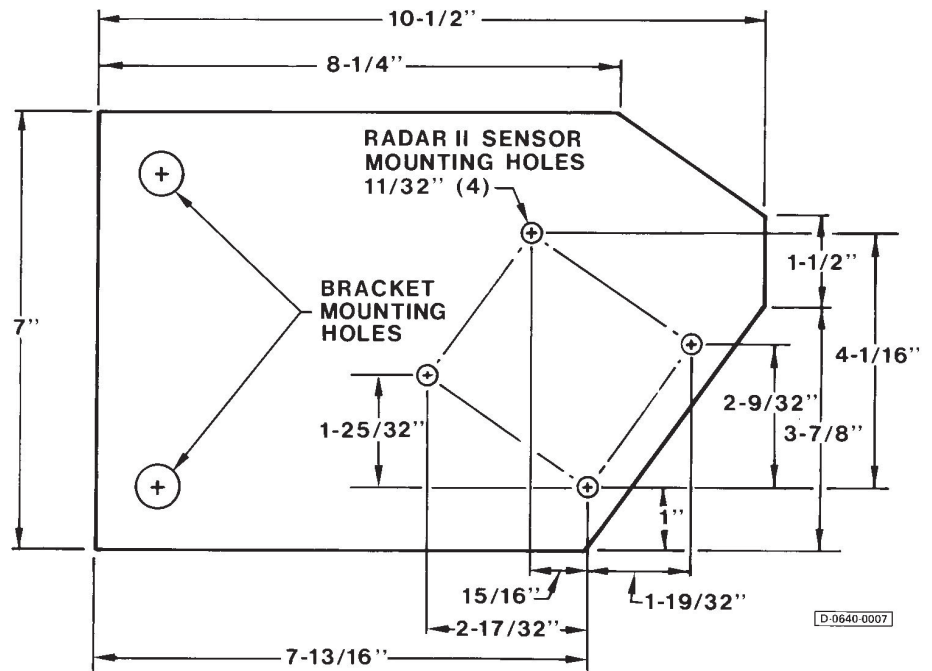

## A. PLATE MOUNTING BRACKET (fabricated by user)

1. Shown above is a dimensional drawing of the plate mounting bracket, which may be fabricated by the installer. The mounting plate must be made out of 5/16 inch steel plate. **IMPORTANT:** Using steel plate less than 5/16 inch may allow the radar velocity sensor to vibrate which could cause erroneous MPH(kph) readings.

Refer to the above illustration and make the flat plate mounting bracket as shown.

**NOTE:** The most critical dimensions are the placement of the four Radar II Sensor mounting holes. However, these holes may be oveled out if they are not drilled in the exact location.

Suggested mounting hardware is as follows.

1. 3/8-16 x 1-1/2" Bolts (2)
2. 3/8 Split Ring Lockwashers (2)
3. 3/8 Nuts (2)
4. 1/4 - 20 x 4" Bolts, SST (4)
5. 1/4 Flatwashers, SST (8)
6. 1/4 - 20 Nuts, SST (4)
7. 1/4 Split Ring Lockwashers, SST (4)
8. 9/32" x 1/2" x 9/10" Spacers (4) (Dj-Part No. 45640-4110)

**IMPORTANT: MAKE CERTAIN THE MOUNTING PLATE DOES NOT EXTEND PAST THE SENSOR HOUSING. METAL BESIDE THE FACE AREA CAN CAUSE IMPROPER OPERATION OF THE SENSORS.**

**IMPORTANT: MAKE CERTAIN THAT THE METAL REAR HOUSING OF THE SENSOR DOES NOT COME IN CONTACT WITH THE VEHICLE FRAME OR THE MOUNTING BRACKET. Such contact can cause erratic readings by introducing electrical noise into the sensor. Under certain circumstances, such contact may cause electrical damage to the sensor.**

# INSTALLATION INSTRUCTIONS

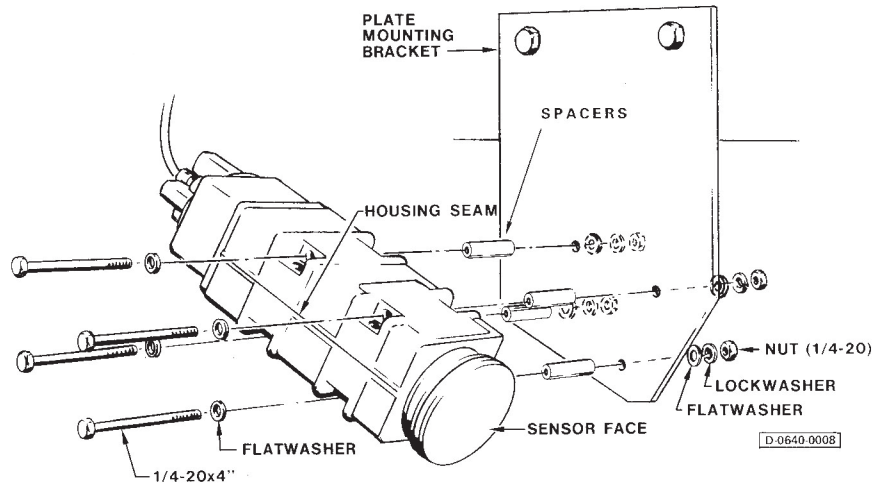

2. Refer to the above illustration and install the DjRVS II Sensor on the flat plate mounting bracket as shown with the enclosure seam on the side. Make certain spacers are installed as shown.

### CAUTION

**DO NOT EXCEED 30-35 LB-IN (3.0-3.5 N.M.) OF TORQUE WHEN TIGHTENING THE FOUR 1/4-20x4 BOLTS SECURING THE RADAR II TO THE MOUNTING BRACKET. OVER TIGHTENING MAY FRACTURE THE RADAR II SENSOR HOUSING.**

**NOTE: WHEN INSTALLING THE DjRVS II RADAR VELOCITY SENSOR MAKE CERTAIN THE SEAM IN THE SENSOR HOUSING IS MOUNTED IN THE HORIZONTAL PLANE AS ILLUSTRATED ABOVE.**

3. Refer to the above illustration and initially drill out the "A" mounting hole. Install a 3/8 inch bolt, lockwasher and nut. Tighten the bolt enough so the mounting plate will hold position without slipping. Tape the alignment template to the radar and using a small carpenter's level rotate the mounting plate until the dotted line on the template is level. Drill out the "B" mounting hole.

**NOTE:** If required, the "B" mounting hole can be oveled out to provide the rotation necessary to adjust the radar angle.

## B. PIPE MOUNTING BRACKET KITS

This mounting bracket kit consists of a mounting plate, two U-bolts with lockwashers and nuts, and four 1/4 - 20 x 4 inch bolts with lockwashers and nuts. This kit is used to install the DjRVS II on the "L" pipe mounting bracket. If the pipe mounting bracket is already installed, proceed to Step 3; otherwise proceed as follows:

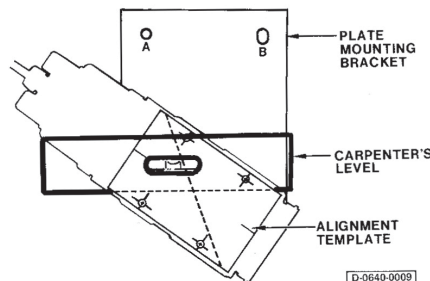

# INSTALLATION INSTRUCTIONS

## TYPICAL MOUNTING LOCATIONS

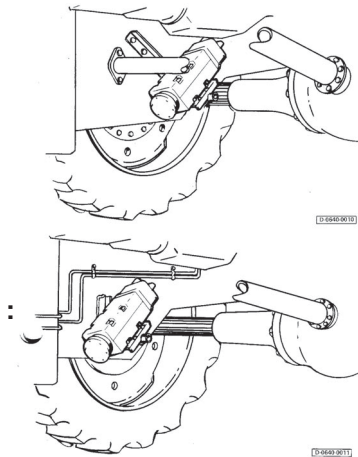

1. Select a location (on inside of main frame when possible) to install the sensor "L" pipe mounting bracket. If possible, select a location where two existing bolts can be used and drill matching holes in the angle iron on the pipe mounting bracket. The two preceding illustrations show some typical mounting positions.
2. If two existing bolts are not at the selected location, drill two holes in the mounting surface and two matching holes in the angle iron on the pipe mounting bracket (check opposite side of drilling surface for wires, hoses, etc.). Before installing the pipe mounting bracket, make certain the sensor can be positioned over the pipe extending from the bracket. If not, the sensor will have to be installed on the pipe before the mounting bracket is secured to the mounting surface.

**IMPORTANT:** Welding the bracket to the mounting surface is **NOT RECOMMENDED**. Excessive frame vibration may necessitate the relocating of the mounting bracket to a more stable location. Also, do not weld the bracket in a location that inhibits the removal of the sensor.

**CAUTION: IF, AT ANY TIME, AN ARC WELDER IS USED ON THE VEHICLE OR ANYTHING CONNECTED TO THE VEHICLE, DISCONNECT ALL POWER AND GROUND LEADS WHICH PROVIDE POWER FOR THE SYSTEM. FAILURE TO DO SO CAN RESULT IN DAMAGED ELECTRONIC COMPONENTS, IN WHICH CASE THE WARRANTY WILL BE VOID.**

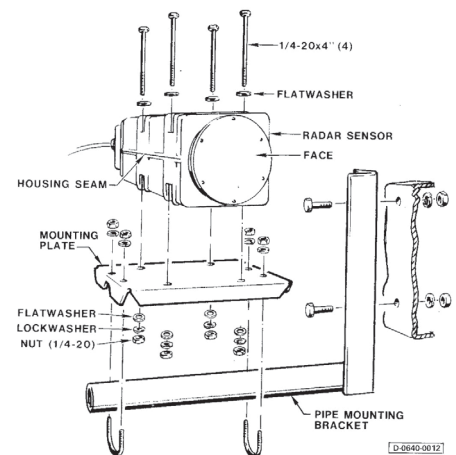

3. Refer to the above illustration and install the sensor mounting hardware as shown. Make sure the sensor is above the pipe with its face towards the rear of the vehicle and the enclosure seam on the side. Tighten the four bolts holding the sensor to the mounting plate. Tighten the U-bolts until the sensor will hold position but can still be adjusted as needed on the pipe.

**CAUTION**  
**DO NOT EXCEED 30-35 LB-IN (3.0-3.5 N.M.) OF TORQUE WHEN TIGHTENING THE FOUR 1/4-20x4" BOLTS SECURING THE RADAR II TO THE MOUNTING BRACKET. OVER TIGHTENING MAY FRACTURE THE RADAR II SENSOR HOUSING.**



# INSTALLATION INSTRUCTIONS

**NOTE: WHEN INSTALLING THE DjRVS II RADAR VELOCITY SENSOR MAKE CERTAIN THE SEAM IN THE SENSOR HOUSING IS MOUNTED IN THE HORIZONTAL PLANE AS ILLUSTRATED ABOVE.**

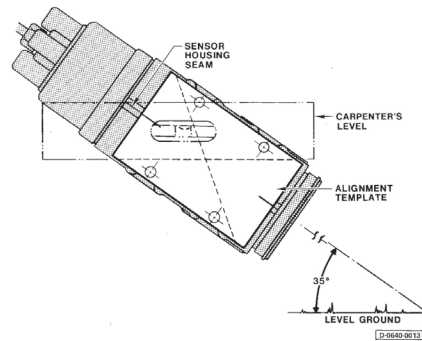

4. Refer to the above illustration and install the sensor angle setting template (template is located at rear of instruction) on the side of the radar sensor as shown. Make certain the short solid lines are lined up with the sensor housing seam. Tape template in place.

Using a level as shown, rotate the sensor on the mounting pipe until the dotted line on the template is level. Tighten the mounting hardware. **NOTE:** The vehicle must be on level ground when the angle is set.

**IMPORTANT:** Make certain that the metal rear housing of the sensor does not come in contact with the vehicle frame or the mounting bracket. Such contact can cause erratic readings by introducing electrical noise into the sensor. Under certain circumstances, such contact may cause electrical damage to the sensor.

5. Route the sensor cable to the location of the console radar cable connector. **NOTE:** Do not secure the cable until sensor has been checked for vibration. Excessive vibration may cause ground speed (MPH) readings to be above zero when the vehicle is stationary. To check for vibration, start vehicle engine and slowly increase engine RPM (while watching the ground speed readout) to approximately 1800. If the ground speed readings are above zero, the sensor must be mounted in an alternate, more stable location. After the sensor readings have been checked and found to be stable, secure the sensor cable where it will not be damaged.

**NOTE:**

When the sensor is installed and the system is operational, the sensor or console must be calibrated.

Refer to the Installation and Operation Manual of your monitor console and perform the ground speed (distance) calibration procedure as described.

# DICKEY-john RADAR VELOCITY SENSOR DJRVS II

## SAFETY INFORMATION

### POWER

#### 12V Version:

Voltage: 13.0V nominal (9.0 – 16.0V)

Current: Less than .60A

#### 24V Version: (Less than 3 meter cable)

Voltage: 26.0V nominal (18.0 – 32.0V)

Current: Less than .63A

### ELECTRICAL PROTECTION

On both versions: Power to be supplied to unit from circuit protected by a 5A automotive type fuse (or less). Reverse Polarity protection built into unit using series diode (Unit is open circuit to reverse polarity on power lines).

### SAFETY



The DJRVS II sensor is an intentional radiator of RF energy. Although its radiated energy level is far below the limits set by EN 61010-1: 1993 \A2: 1995 – Chapter 12.4, it is advisable not to look directly into the face of the unit.

### MAINTENANCE

The Dickey-john Radar Velocity Sensor DJRVS II requires no periodic maintenance. It has been designed to withstand typical environmental conditions found on the under-side of an agricultural tractor or vehicle. If the sensor is spray washed, do not exceed 65 Bars of pressure and maintain a distance of at least 1 meter.

#### MANUFACTURER

DICKEY-john Corp  
5200 Dickey-john Road  
Auburn, Illinois 62615  
USA  
Tel: 217 438 3371  
Fax 217 438 6012

#### EUROPEAN SUBSIDIARY

DICKEY-john EUROPE S.A.  
165, Boulevard de Valmy  
92706 Colombes  
France  
Tel: 33 1 41 19 21 80  
Fax: 33 1 47 86 00 07



# INSTALLATION INSTRUCTIONS

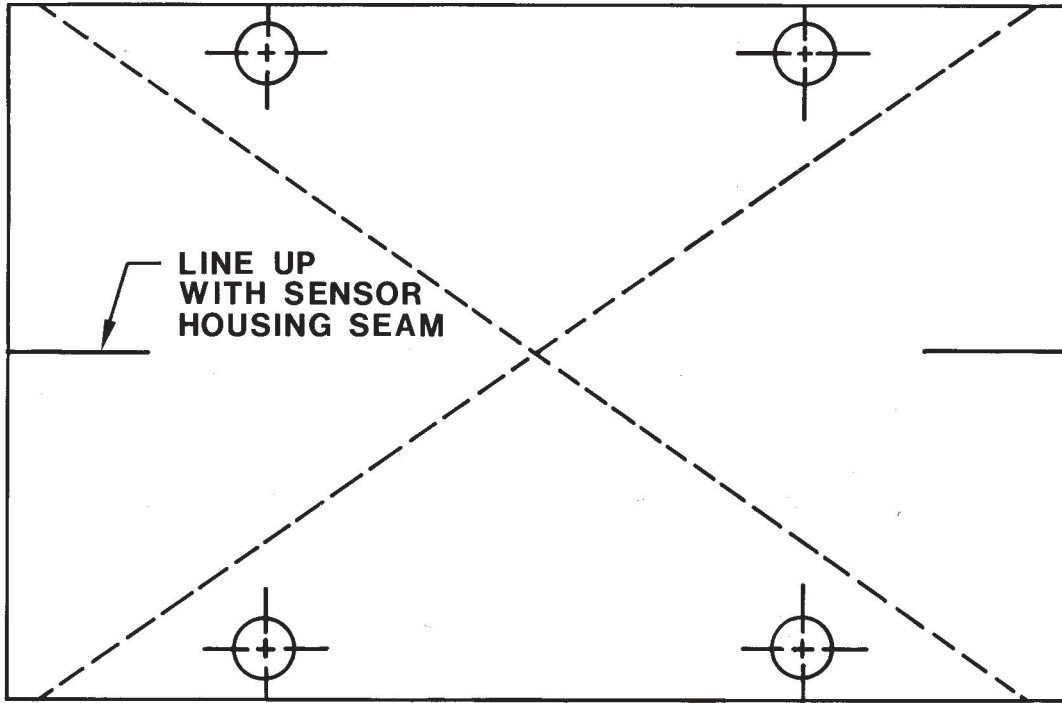

CUT ON  
OUTSIDE  
SOLID LINE

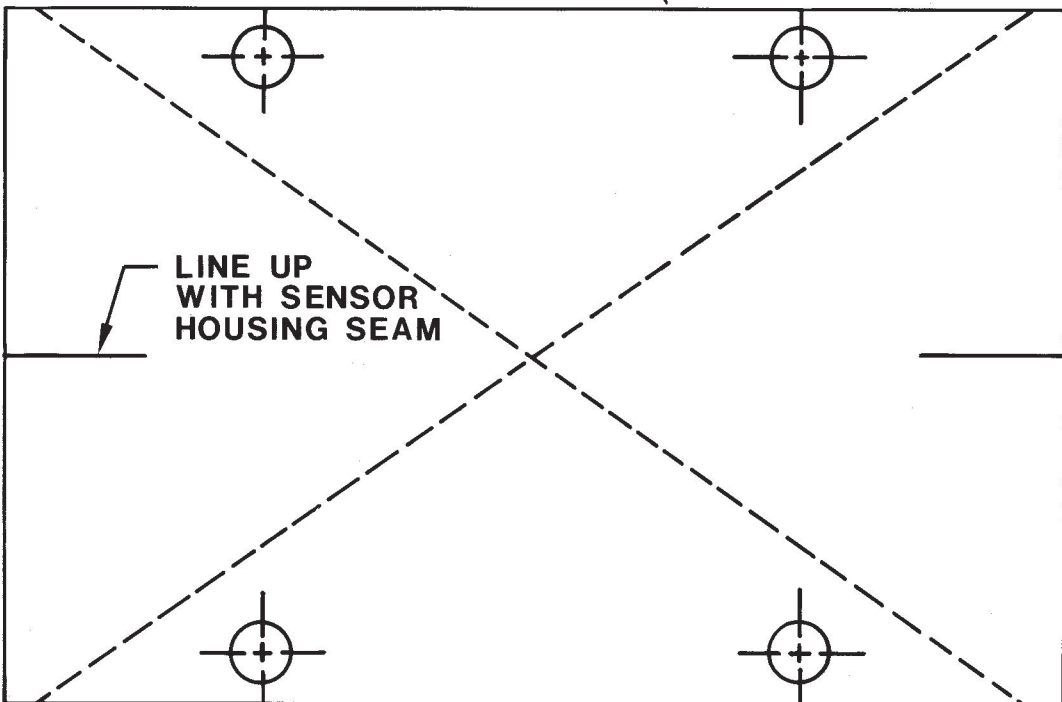

**UNIVERSAL RADAR SENSOR ANGLE SETTING TEMPLATE**

D-0640-0014