

# SEED MANAGER® SE



OPERATOR'S MANUAL



**DICKEY-john**<sup>®</sup>  
CORPORATION

*Revolutionizing Electronics*

<b>Safety Notices</b> .....	<b>1</b>
<b>Introduction</b> .....	<b>3</b>
System Overview .....	3
<b>Installation and Setup</b> .....	<b>5</b>
Console Mounting .....	5
Console Harness Installation .....	6
Power Connection .....	7
Implement Harness Connection .....	9
Installation Steps .....	14
<b>Startup</b> .....	<b>19</b>
SwitchPad Overview .....	19
Setup Mode .....	22
<b>Operation</b> .....	<b>43</b>
Operate Mode .....	43
Run Hours .....	43
Population .....	44
Population Scan .....	44
<b>Alarms</b> .....	<b>51</b>
<b>Self Test error codes</b> .....	<b>59</b>
<b>Troubleshooting</b> .....	<b>61</b>
Monitor Dead .....	61
Battery Symbol Appears On Display .....	61
Error Code E00 .....	61
Error Code E01 .....	62
Error Code E10 .....	62
Error Code E11 .....	63
Error Code E20 .....	63
Error Code E21 .....	63
Error Code E30 X .....	64
Error Code E31 X .....	64
Error Code E40 .....	64
Error Code E41 .....	65
Error Code E50 .....	65
Error Code E51 .....	66
Error Code E70 .....	66
Error Code E71 .....	66
Error Code E98 – E99 .....	66
<b>Connector Pin Outs</b> .....	<b>67</b>
<b>Setup Record Sheet</b> .....	<b>69</b>



## SAFETY NOTICES

Safety notices are one of the primary ways to call attention to potential hazards.



**This Safety Alert Symbol identifies important safety messages in this manual. When you see this symbol, carefully read the message that follows. Be alert to the possibility of personal injury or death.**

---

### **⚠ WARNING**

Use of the word **WARNING** indicates a potentially hazardous situation which, if not avoided, could result in death or serious injury.

---

### **⚠ CAUTION**

Use of the word **CAUTION** with the Safety Alert Symbol indicates a potentially hazardous situation which, if not avoided, may result in minor or moderate injury.

---

### **CAUTION**

Use of the word **CAUTION** without the safety alert symbol indicates a potentially hazardous situation which, if not avoided, may result in equipment damage.

---



## INTRODUCTION

### SYSTEM OVERVIEW

The Seed Manager<sup>®</sup> SE System offers new features such as the ability to monitor up to ninety six (96) seed rows, two (2) Fan (RPM) inputs, three (3) Shaft Speed (RPM) inputs, two (2) Pressure inputs, seven (7) hopper level inputs, and a Ground Speed input. It is compatible with DICKEY-john Standard and Hi-Rate seed sensors. The monitor will store all implement configuration data in nonvolatile memory, retaining information even when disconnected from the tractor battery. Figure 1 shows the Seed Manager<sup>®</sup> SE console.

*Figure 1*

*SeedManager<sup>®</sup> SE Console*





## INSTALLATION AND SETUP

### CONSOLE MOUNTING

The console should be mounted inside the tractor cab in a location accessible to the operator but does not obstruct the driving view. Figure 2 depicts typical console mount.

*Figure 2*

*Typical Console Mounting using the U-bracket and hardware*

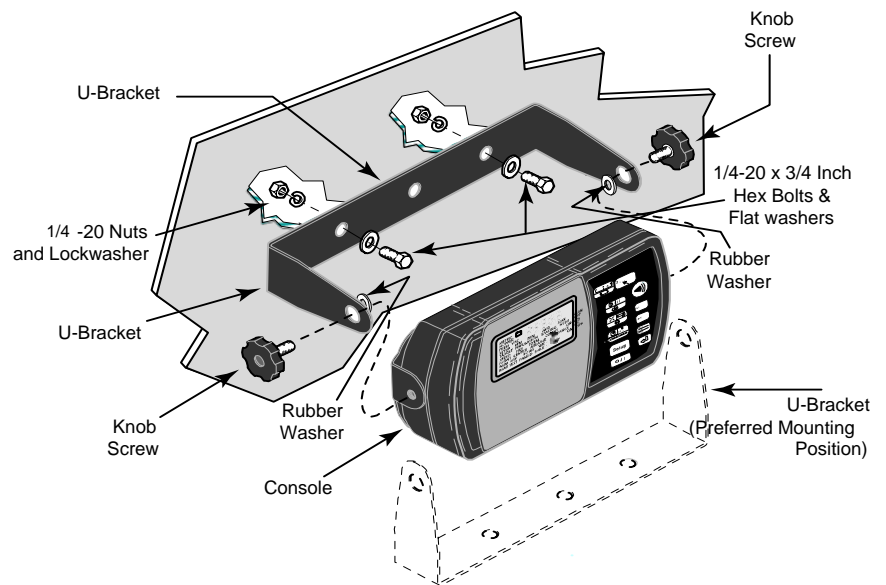

### MOUNTING STEPS

1. Verify the rear side of the selected mounting surface is free of wiring or other obstructions and is accessible for inserting and tightening the mounting bolts.
2. Use the U-shaped mounting bracket as a template to mark the two outside holes of the bracket on the selected location and drill two 9/32 inch holes. An alternate mounting method, which allows the console to swivel, requires drilling the center bracket hole only.
3. Attach the mounting bracket to the mounting surface using the 1/4 - 20 x 1/2 inch bolts, lockwashers, flatwashers, and nuts.
4. Secure the console to the mounting bracket using the two knob screws. Insert the two rubber washers between the bracket and console.
5. Tilt console so that the J1 connector on the rear of the console is accessible. Temporarily tighten the two knob screws.

## CONSOLE HARNESS INSTALLATION

The J1 connector on the back of the console connects all input and output signals to the Seed Manager<sup>®</sup> SE console.

The primary tractor harness is shown in Figure 3. This harness contains connectors for a ground speed sensor (digital), a ground speed sensor (reluctance), system power, and P1 and P2 Bus connectors. A secondary module harness is used to connect to P1 and/or P2.

For systems that contain a J2 connector, a separate accessory harness will contain a RS-232 connector for PC/GPS applications.

*Figure 3*  
*Primary Tractor Harness*

**Note:**

Due to the power requirements for the Seed Manager<sup>®</sup> SE system, the battery connections must be made directly to the tractor battery.

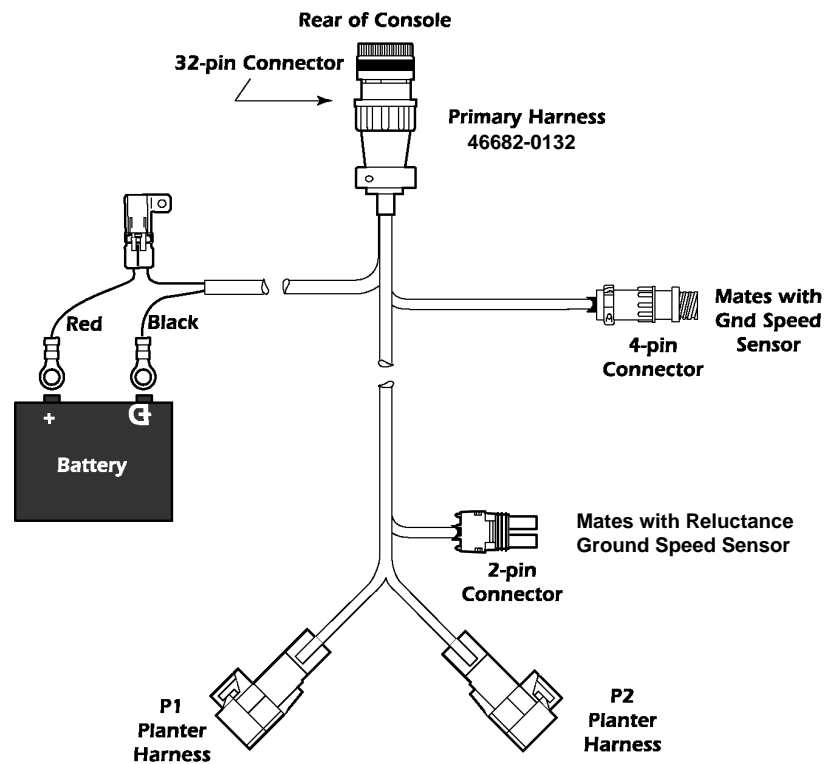

Install the primary (J1) harness from the rear of the console to the tractor hitch as follows:

**Note:**

Due to the power requirements for the Seed Manager<sup>®</sup> SE system, the battery connections must be made directly to the tractor battery.

1. Route the primary harness from J1 on the console rear to the rear of the tractor, near the hitch. Route it on the side of the tractor opposite the alternator and spark plugs. Locate the harness to prevent being pinched, cut, or stepped on and secure it with wire ties.
2. Install or connect an existing ground speed sensor. The ground speed sensor may be one of three types – radar, reluctance, or Hall Effect. A radar sensor or reluctance sensor connects directly to the designated connector on the primary harness. A Hall Effect sensor may require an adapter harness to connect to the primary harness. Sensor mounting instructions accompany the sensor. Select the mounting location and install as the instructions describe.
3. Refer to Implement Harness instructions on page 9 to install Module and Sensor Harnessing.

## **CAUTION**

**Power connections should be made last to avoid accidental shorts during harness installation.**

---

## POWER CONNECTION

The Seed Manager<sup>®</sup> SE System operates on 12 volts DC only. The battery connections on the primary harness consist of two wires, each terminated with a ring terminal.

Before making the battery connections, determine the tractor battery arrangement from Figures 4, 5, and 6. After the 12 volt source is known, connect the black wire directly to the negative (-) terminal of the battery. The red wire (containing the fuse link) connects directly to the positive (+) battery terminal. Make sure the connections are clean and tight. Do not route these wires in close proximity to the existing battery cables. Secure the battery wires with wire ties.

If your tractor battery arrangement differs from that shown or if in any doubt exists about how to connect to the battery, use a voltmeter first. Verify 11 to 14 volts across the battery connection points. On tractors using two batteries, be sure to make connections to the grounded battery.

*Figure 4*  
*12V Battery Source Connections*

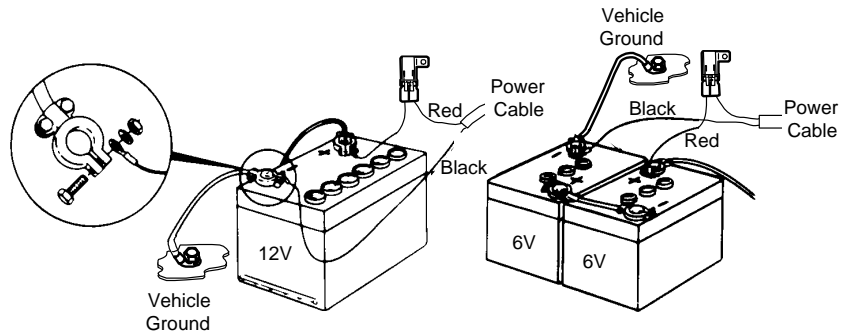

*Figure 5*  
*24V Battery Source Connections*

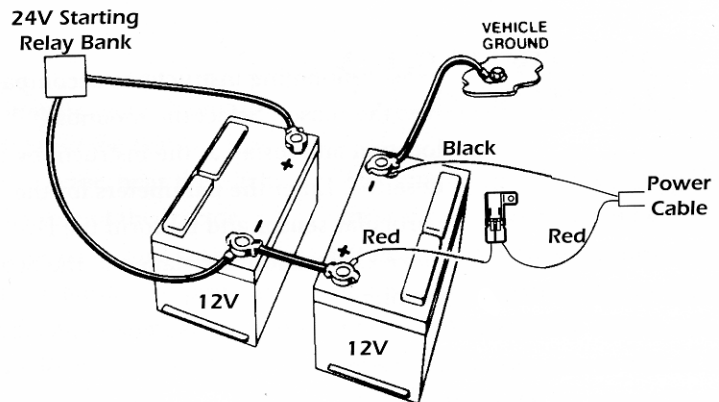

*Figure 6*  
*Negative or Positive Source Connections*

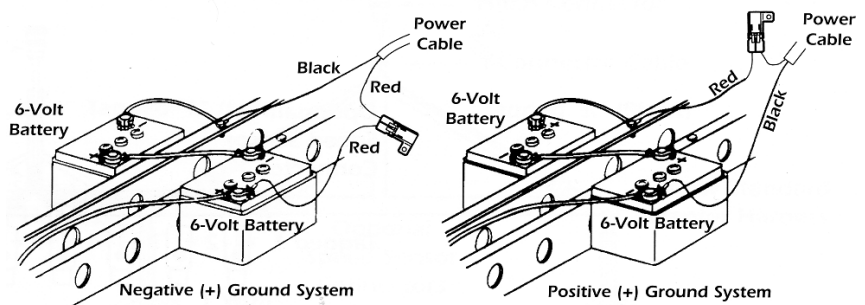

**IMPORTANT:** Before welding on the frame or chassis, be certain to disconnect battery leads. Failure to do so could result in damage to the Seed Manager® SE.

## IMPLEMENT HARNESS CONNECTION

The Seed Manager® SE System uses any combination of three basic module types, each with their own specific harness configuration. There are 12 Row Material Flow Modules, 16 Row Material Flow Modules, and a Shaft Speed Module. A single Bus cable connects to each module then serially (daisy chains) connects to following modules. The primary harness divides into two halves at the implement hitch (P1 and P2). The following requirements must be observed when connecting modules to the bus:

1. A maximum of six Material Flow Modules can be connected to the bus.
2. Only one Shaft Speed Module may be connected to the bus. The Shaft Speed Module may be connected anywhere on the bus that is convenient. It can be connected to either P1 or P2.
3. No more than three Material Flow Modules can be connected to P1 or P2.
4. Any combination of 12 Row or 16 Row Material Flow Modules may be used.

The order in which the Material Flow Modules are connected and their position on the toolbar or implement is important to note. The Material Flow Modules are identified by the console as **b1, b2, ...bn** (where *n* is the total number of Material Flow Modules connected). The order in which the console identifies the modules depends upon how they are connected to the bus. The following figures show example system configurations and how the Console identifies the modules connected for each configuration. Note order of the modules in relation to how they connect to the bus.

**Figure 6A**

*Four Module Setup (two modules are connected to P1 and two to P2)*

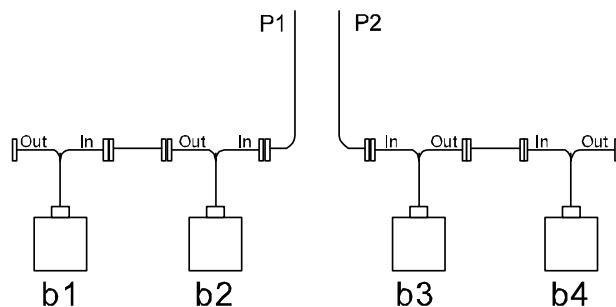

**Figure 6B**

*Three Module Setup (All modules are connected to P1).*

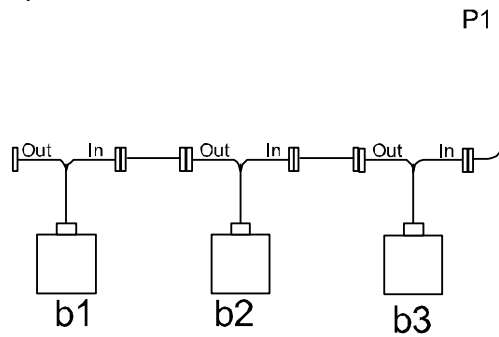

**Figure 6C**

*Three Module Setup (One module is connected to P1 and two are connected to P2).*

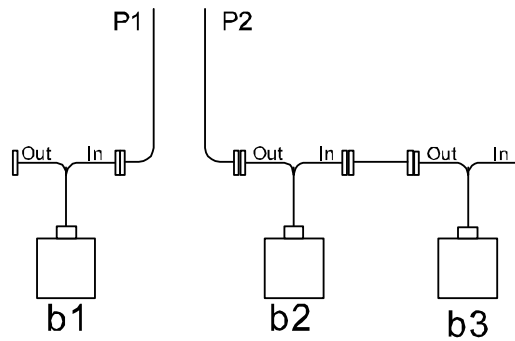

**Figure 6D**

*Two Module Setup (One module is connected to both P1 and P2).*

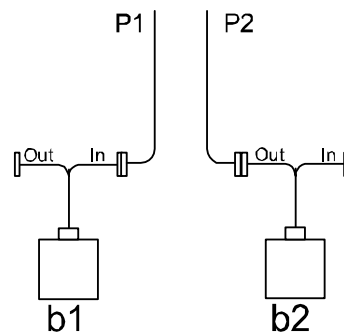

**Figure 6E**

**Two Module Setup (Three modules are connected to P1 and two are connected to P2)**

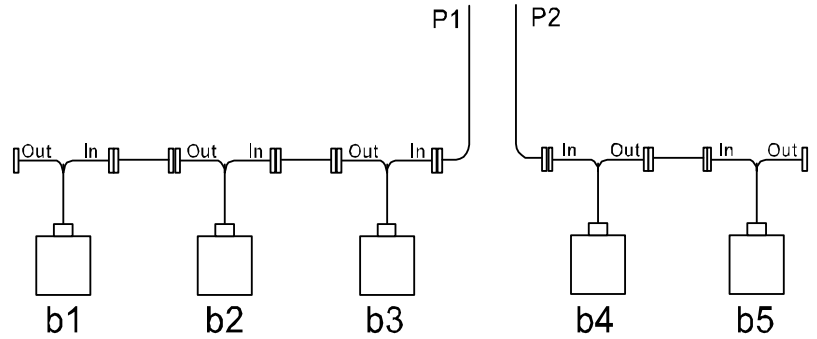

As the previous examples show, b1 is always identified as the LAST module connected to P1. The remaining modules on P1 are numbered sequentially, along with any modules connected to P2.

When connecting sensors to the Material Flow Modules, the following requirement must be observed:

1. All seed sensors installed on a Material Flow Module must be connected sequentially starting with Row 1 as shown below.

**Figure 6F**

**Correct Install**

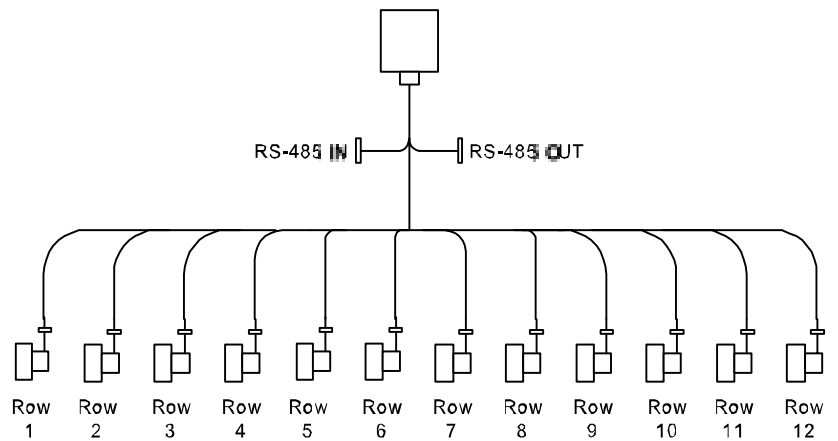

**Figure 6G**

*Correct Install*

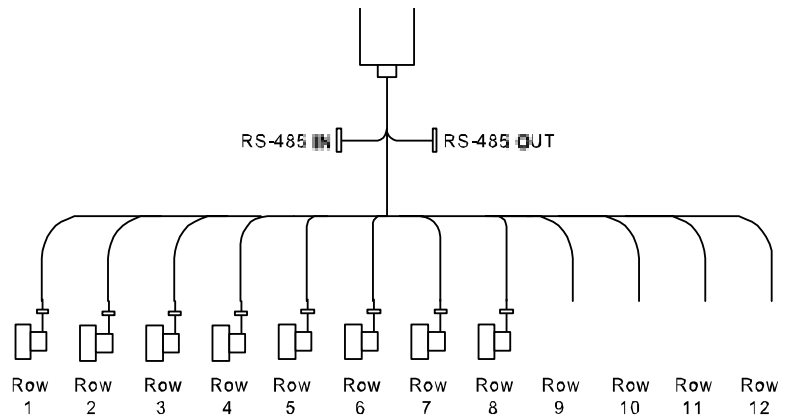

There can be no skips in the row inputs on a Material Flow Module. The following shows the previous eight row module setup incorrectly.

**Figure 6H**

*Incorrect Install*

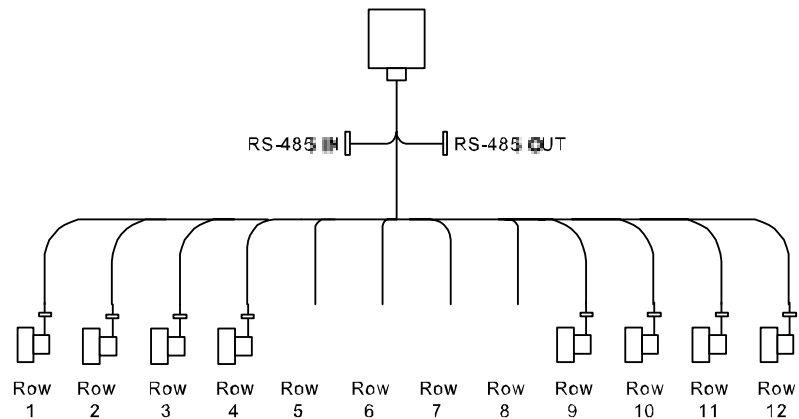

Follow the same examples on all Material Flow Modules used in the system. When correctly connected, row 1 sensor should be connected to the Row 1 input on **b1**. The monitor will then number the sensors from 1 to *n* starting on **b1**, then **b2**, and so on.

Hopper level sensors can be connected to 12 Row Material Flow Modules. Hopper sensors can be connected to either of the hopper inputs on a Material Flow Module. The monitor will identify the number of hopper sensors connected to each Material Flow Module and will number them from 1 to  $n$  starting with any sensors connected to **b1**. If no sensors are connected to **b1**, the number starts from **b2** and so on. In the event that two hopper sensors are connected to a given module, the sensor connected to input 1 is numbered before the sensor connected to input 2. The following shows an example configuration with hopper sensors connected and how they would be identified by the console.

**Figure 6I**

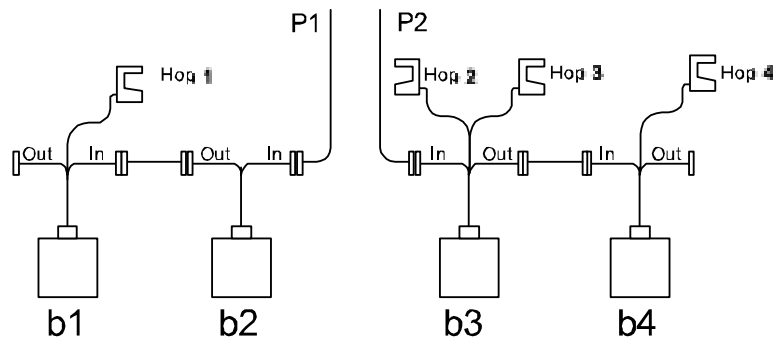

When hopper level sensors are connected to a Shaft Speed Module, they are numbered relative to the position of the Shaft Speed Module on the bus. If the Shaft Speed Module is connected to the RS-485 out of **b1**, the numbering of the hopper sensors starts with this module, then continues with any hopper sensors connected to **b1**, **b2**, etc. If the Shaft Speed Module is connected between Material Flow Modules, any hopper sensors connected are numbered in the order in which they are detected as shown below.

**Figure 6J**

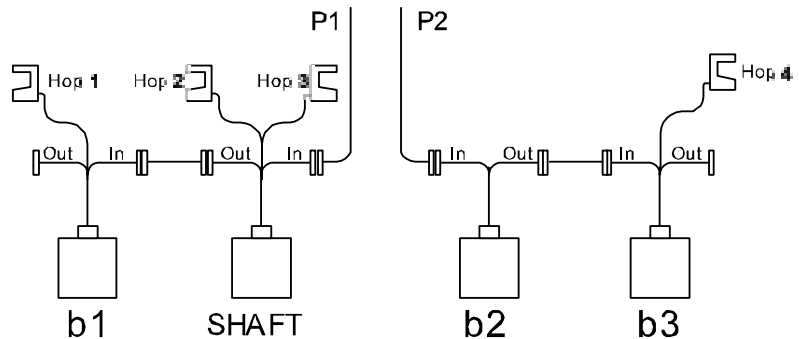

Shaft, fan, and pressure sensors can only be connected to the Shaft Speed Module. These sensors are identified by the monitor according to what input they are connected to regardless of the position of the Shaft Speed Module on the bus.

Figure 6K shows a complete example system setup and how each connected sensor would be identified.

## INSTALLATION STEPS

1. Mount each of the modules to the toolbar or implement in a location that will minimize vibration and will allow for easy access to harness hookup.
2. Lay out each module harness along the frame of the implement to each of the seed rows (or appropriate sensors). Secure the harness to the toolbar.
3. Install and/or connect each of the seed sensors (or appropriate sensor). Sensor mounting instructions accompany the sensor. Select the mounting location and install as described in the instructions.
4. Connect each module together with a bus harness. Finally, connect the tractor harness P1 and P2 connectors to the bus harness. Coil and secure existing cables with wire ties to avoid pinching or damage to the harness.

Figure 6K

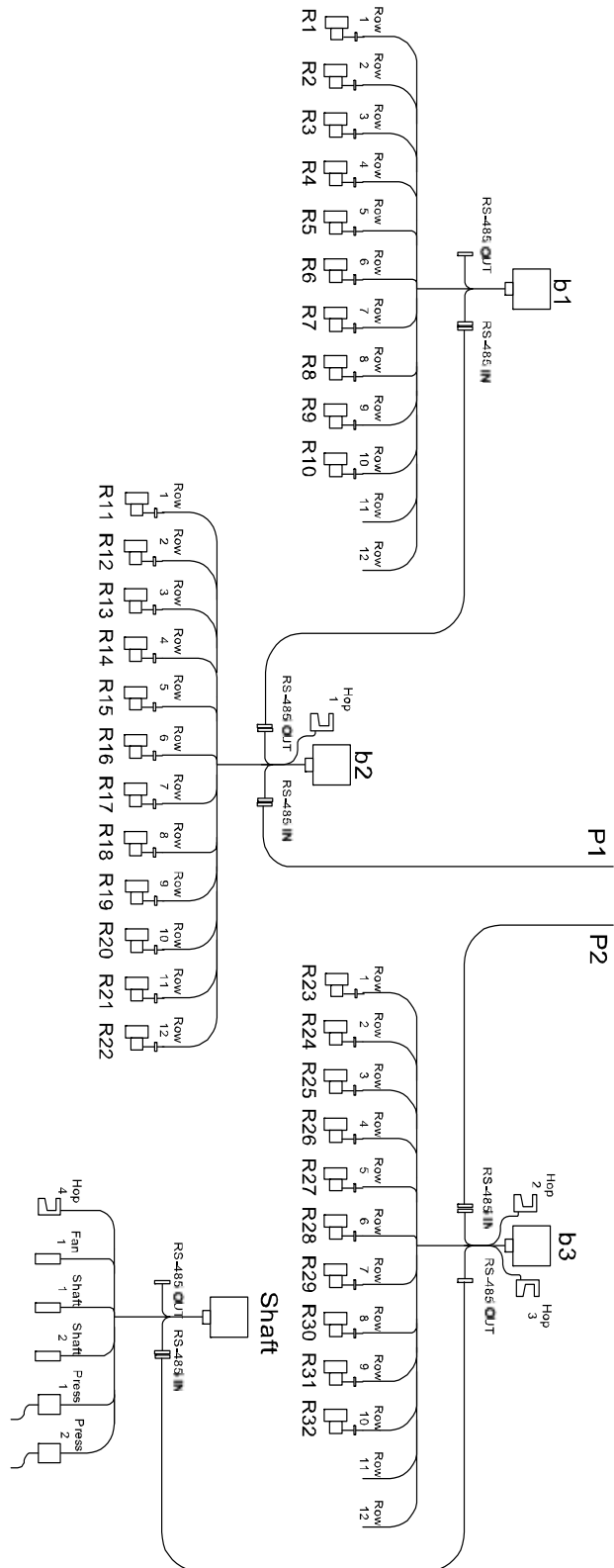

**Figure 6L**  
*12 Row Harness*

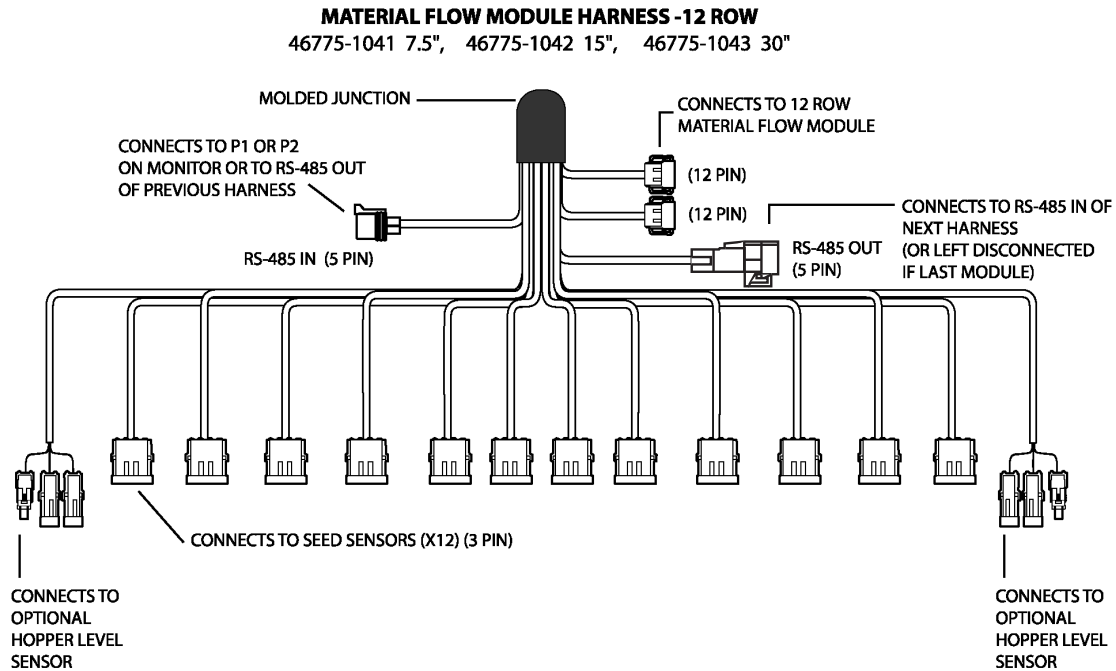

**Figure 6M**  
*16 Row Harness*

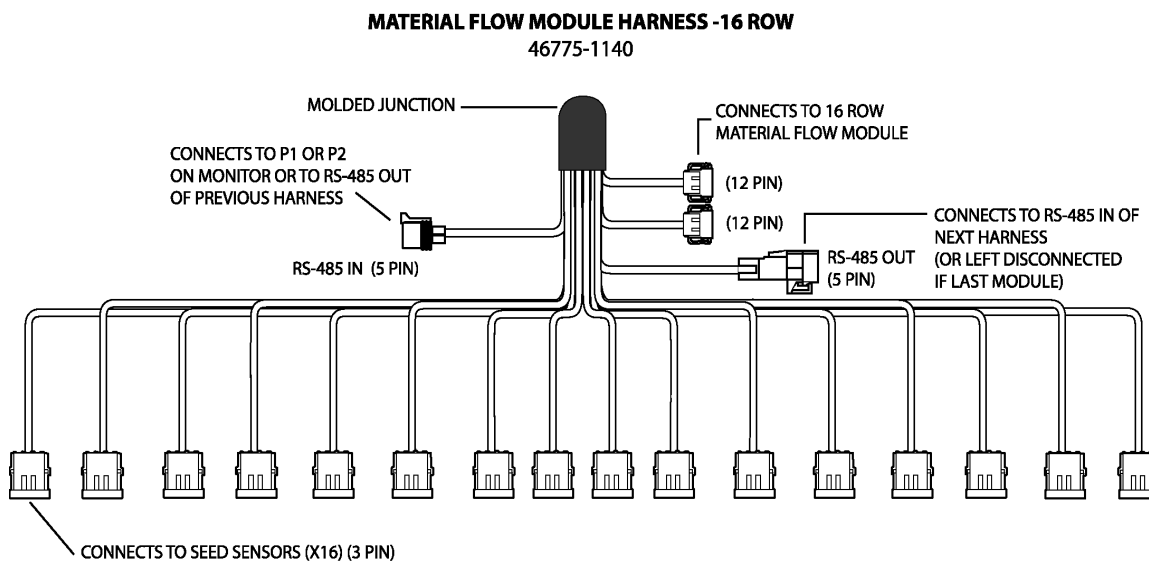
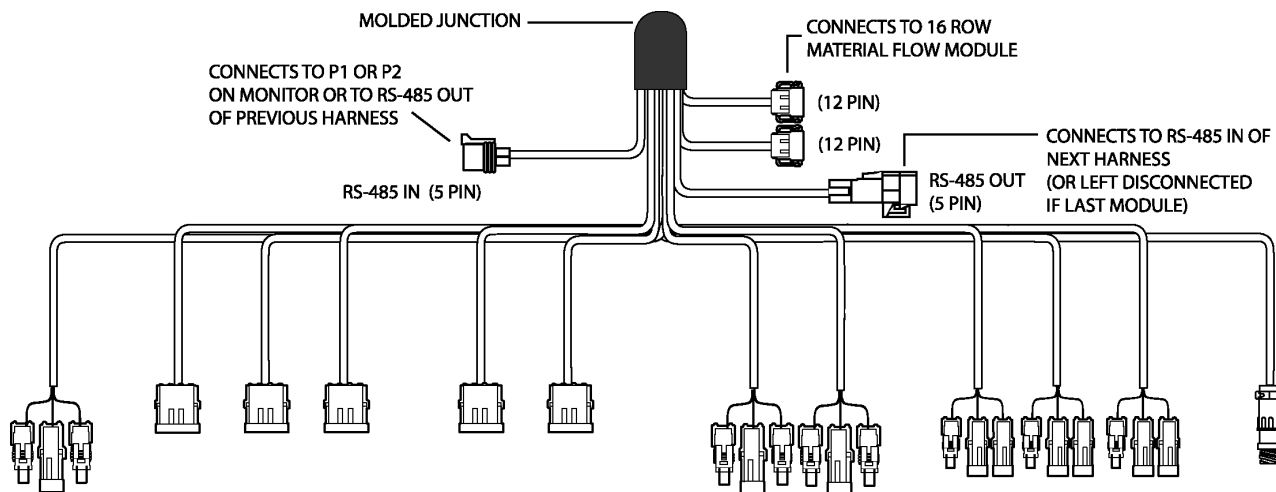

**Figure 6N**

*Shaft Speed Module Harness*

**SHAFT SPEED MODULE HARNESS**

46775-2040



**Figure 6O**

*RS-485 Extension Harness*

**RS-485 EXTENSION HARNESS**

- 46882- 0510 3'
- 0511 6'
- 0512 10'
- 0513 15'
- 0514 20'
- 0516 30'
- 0517 40'

CONNECTS TO P1 OR P2  
OF MONITOR OR TO RS-485 OUT  
OF PREVIOUS HARNESS

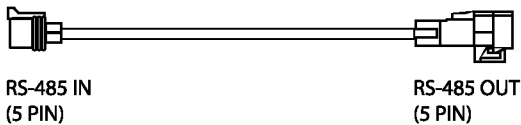

CONNECTS TO RS-485 OF  
NEXT HARNESS



## STARTUP

### SWITCHPAD OVERVIEW

The control pad buttons on the switchpad are used to control system power, select the mode of operation, and enter implement configuration constants. To help distinguish between switch names and display messages in the text of this manual, switch names are always shown in italicized print. An overview of the switches follows:

#### ON OFF

Pressing this switch applies power to the monitor. Upon power up, the monitor performs internal diagnostic checks, illuminates all segments of the LCD, sounds the alarm, and determines what sensors are connected to the system. Depressing the ON OFF switch for at least one (1) second causes the system to power down.



#### ALARM

Momentarily pressing this switch silences the alarm and acknowledges the alarm condition. Additionally, holding the switch pressed for more than one (1) second allows the volume level of the alarm to be adjusted. As the switch is pressed, the alarm sounds continuously and the volume level slowly decreases to a minimum, then increases to a maximum. Releasing the switch establishes the desired volume level.

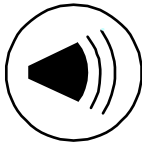

#### SETUP

This switch is pressed for one (1) second to enter the Setup Mode and to step from one Setup constant to the next as detailed in the Setup Mode Chapter.



#### MIN AVG MAX SCAN

This switch is pressed to toggle between the MIN AVG MAX and SCAN options for Population and Spacing.

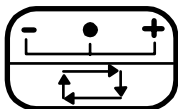

#### SELECT ROW

Pressing this switch while in Population or Spacing functions freezes the display on the current row data. Successive depressions then cause stepping from one row to the next. In the Setup Mode, this switch allows stepping through the rows while entering Row Status.

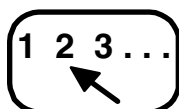



## SELECT

This switch is used to change constants in the Setup Mode as explained in the Setup Mode chapter. To move the selected digit to the next digit, press the SELECT switch.



## SET

This switch is used to change constants in the Setup Mode as explained in the Setup Mode chapter. To increase the selected digit by one, press the SET switch. SET can also toggle a selection between ON and OFF for example.



## START STOP RESET

This switch is used in multiple modes for multiple purposes. Some examples are as follows. This switch is used in the Operate Mode Seed Count and Distance Accumulator functions to start or stop the accumulations. It is also used in Setup Mode Distance Calibration, Automatic Configuration, and Sensor Self Test functions to start or stop the test. Other functions include Clearing the Run Hours, Area Accumulators, Seed Count, Distance Accumulator, and simply clearing digits when editing Setup constant values.

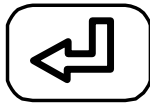

## BACK

This switch is used in multiple modes for multiple purposes. Some examples are as follows. This switch is used in the Operate Mode Population and Spacing functions to step to the previous row display. It is also used in Setup Mode to return to the previous Setup Mode screen.

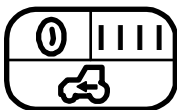

## OPERATE 1

This switch is used to select Population, Spacing, or Ground Speed Mode. Successive presses of the switch will change to the next mode.

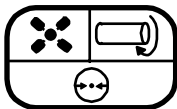

## OPERATE 2

This switch is used to select Fan Speed, Shaft Speed, or Pressure Mode (if available on system). Successive presses of the switch will change to the next mode.

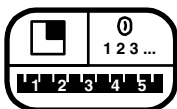

## OPERATE 3

This switch is used to select Area, Seed Count, or Distance Accumulator Mode. Successive presses of the switch will change to the next mode.

## SETUP MODE

### SETUP CONSTANTS

The Setup Mode is used to enter the implement configuration constants which are listed in Figure 7, in the order of their presentation. Depressing the Setup switch for one (1) second places the console in the Setup Mode, which is identified by the SETUP message on the display. Additional messages uniquely identify the constant displayed and available for editing at any given time.

Each constant has a fixed number of digits. Leading zeroes are displayed. When it is desired to change the value of a constant, use the SELECT, SET, and START STOP RESET switches as follows:

Initially the left most digit flashes on and off, indicating it is the "selected digit". Each depression of the SET switch increases the selected digit by one count. After reaching the maximum value of nine (9), the digit rolls over to zero (0). Pressing START STOP RESET zeroes the digit. Each depression of the SELECT switch makes the next digit to the right the selected digit.

When the desired value is entered (or there is no change from the original value), press the Setup switch to store the value and advance to the next constant on the list. To return to the previous constant on the list, press the BACK switch. If a value is entered which exceeds the minimum or maximum shown for that constant in Figure 7, the alarm sounds for one (1) second, the value of the exceeded limit appears on the screen, and the advance to the next constant is aborted.

*NOTE: To allow rapid recovery from an entry error, it is important to record all values of constants on the SETUP RECORD sheet on the last page of this manual, immediately after console entry.*

Figure 7

Setup Mode Parameters

**IMPORTANT:**

If the Number of Seed Modules, Number of Fan Speed Sensors, Number of Shaft Speed Sensors, or Number of Pressure Sensors is set to "0" or another value below the maximum, the appropriate subcategory screens will not be displayed.

Order	Setup Mode	Default	Minimum	Maximum
1	Seed Flow	00	00	10
2	Population Hi Limit	0034.0	0000.0	9999.9
3	Population Lo Limit	0026.0	0000.0	9999.9
4	Row Width	030.0	001.0	999.9
5	Implement Width	N/A	0001.0	9999.9
6	Ground Speed Source	d1	N/A	N/A
7	Distance Calibration	6096	250	9999
8	Automatic Configuration	N/A	N/A	N/A
9	Split Row Configuration	00	00	20
10	Number of Seed Modules	1	1	6
10A	Number of Seed Sensors Module 1	01	01	16
10B	Number of Seed Sensors Module 2	01	01	16
10C	Number of Seed Sensors Module 3	01	01	16
10D	Number of Seed Sensors Module 4	01	01	16
10E	Number of Seed Sensors Module 5	01	01	16
10F	Number of Seed Sensors Module 6	01	01	16
11	Row Status	ON	N/A	N/A
12	Total Number of Rows Configured	N/A	01	96
13	Number of Fan Speed Sensors	0	0	2
13A	Fan Speed Sensor 1 Constant	000.0	000.0	999.99
13B	Fan Speed Sensor 1 Hi Limit	00065	00000	99999
13C	Fan Speed Sensor 1 Lo Limit	00045	00000	99999
13D	Fan Speed Sensor 2 Constant	000.0	000.00	999.99
13E	Fan Speed Sensor 2 Hi Limit	00065	00000	99999
13F	Fan Speed Sensor 2 Lo Limit	00045	00000	99999
14	Number of Shaft Speed Sensors	0	0	3
14A	Shaft Speed Sensor 1 Constant	000.00	000.00	999.99
14B	Shaft Speed Sensor 1 Hi Limit	00065	00000	99999
14C	Shaft Speed Sensor 1 Lo Limit	00045	00000	99999
14D	Shaft Speed Sensor 2 Constant	000.00	000.00	999.99
14E	Shaft Speed Sensor 2 Hi Limit	00065	00000	99999
14F	Shaft Speed Sensor 2 Lo Limit	00045	00000	99999
14G	Shaft Speed Sensor 3 Constant	000.00	000.00	999.99
14H	Shaft Speed Sensor 3 Hi Limit	00065	00000	99999
14I	Shaft Speed Sensor 3 Lo Limit	00045	00000	99999
15	Number of Hopper Sensors	0	0	7
16	Number of Pressure Sensors	0	0	2
16A	Pressure Sensor 1 Hi Limit	000.0	000.0	999.9
16B	Pressure Sensor 1 Lo Limit	000.0	000.0	999.9
16C	Pressure Sensor 2 Hi Limit	000.0	000.0	999.9
16D	Pressure Sensor 2 Lo Limit	000.0	000.0	999.9
17	Blockage Mode Configuration	0	0	2
18	Population Filter	00	00	99
19	Population Scalar	100	001	999
20	Sensor/Module Self-Test	N/A	N/A	N/A
21	English/Metric Units	English	N/A	N/A

To exit the Setup Mode, press any of the three Operate switches. Exiting automatically stores the last constant changed.

Definitions and considerations when entering values for each constant are as follows:

## 1. SEED FLOW ALARM ADJUSTMENT

The first parameter displayed after entering the Setup Mode is Seed Flow Alarm Adjustment identified as "SF" on the top of the display. The Seed Flow Alarm Adjustment establishes how many seeds per time interval must flow past the sensor before the alarm is activated identifying a row failure. The default value is 00 which requires a minimum seed flow of at least 2 seeds per second before row failure alarm activates. The maximum value allowed is at least 1 seed every 10 seconds. Figure 8 indicates a minimum of 1 seed every 4 seconds before row failure alarm will sound. Below Seed Flow Alarm Values table lists the values and the relative time intervals. Any number higher than 10 will default to the maximum value of 10.

*Figure 8*

*Seed Flow Alarm Adjustment Display*

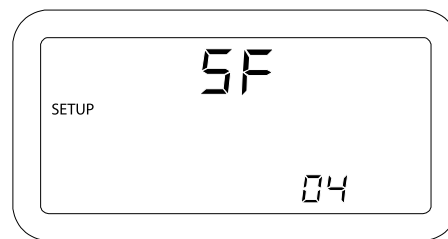

*Seed Flow Alarm Values*

00	2 seeds per second (default)
01	1 seed per second
02	1 seed every 2 seconds
03	1 seed every 3 seconds
04	1 seed every 4 seconds
05	1 seed every 5 seconds
06	1 seed every 6 seconds
07	1 seed every 7 seconds
08	1 seed every 8 seconds
09	1 seed every 9 seconds
10	1 seed every 10 seconds

*Figure 9*

*Population Hi Limit Display*

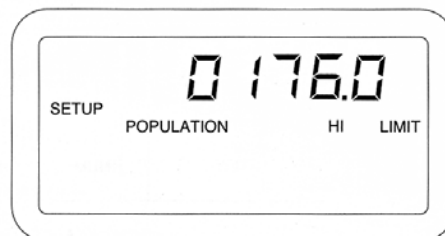

## **2. POPULATION HI LIMIT**

When the population on any row exceeds the value entered for this constant, in thousands of seeds per acre (hectare), the alarm sounds, as indicated under the heading ALARMS, POPULATION HI LIMIT WARNING. Figure 9 shows the display for a limit of 176,000 seeds/acre.

*Figure 10*

*Population Lo Limit Display*

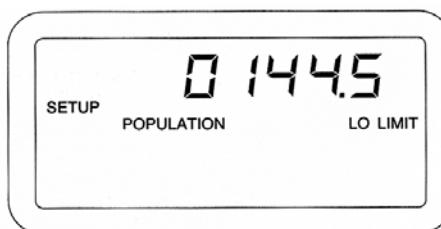

## **3. POPULATION LO LIMIT**

When the population on any row falls below the value entered for this constant, in thousands of seeds per acre (hectare), the alarm sounds, as indicated under the heading ALARMS, POPULATION LO LIMIT WARNING. Figure 10 shows the display for a limit of 144,500 seeds/acre.

*Figure 11*  
*Row Width Display*

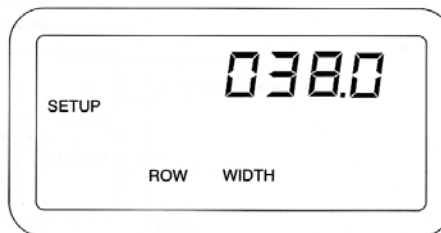

## 4. ROW WIDTH

This is the distance in inches (centimeters) between rows, with a resolution of 0.1. Figure 11 shows a Row Width of 38.0 inches.

*Figure 12*  
*Implement Width*

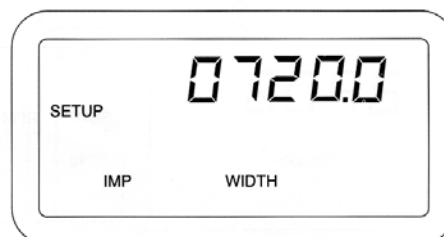

## 5. IMPLEMENT WIDTH

This is the seeding width of the implement in inches (centimeters) with a resolution of 0.1. It is automatically calculated when either the Number of Modules, Number of Rows per Module, or the Row Width is changed and can be edited for special applications such as skip row seeding. Figure 12 shows an Implement Width of 720.0 inches.

*Figure 13*

*Ground Speed Sensor Type Display*

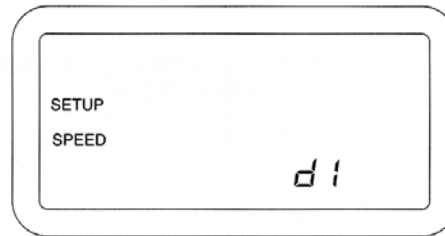

## 6. GROUND SPEED SOURCE

Pressing the Set switch causes the lower right display to toggle between “d1”, “r1”, or “d2”. If a digital (radar or Hall Effect) type ground speed sensor is used, and is connected directly to the Seed Manager<sup>®</sup> Console, press the SET switch until “d1” appears. If a digital (radar or Hall Effect) type ground speed sensor is used, and is connected to a Shaft Speed Module, press the SET switch until “d2” appears. If a reluctance type ground speed sensor is used press the SET switch until “r1” appears. Figure 13 shows a configuration for a digital 1 ground speed source.

*Figure 14*

*Distance Calibration Display*

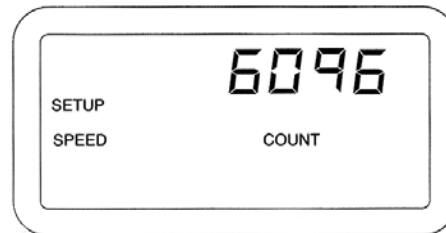

## 7. DISTANCE CALIBRATION

The Distance Calibration constant is the number of pulses generated by the ground speed sensor while traveling a distance of 400 feet (122 meters). Figure 14 shows the display with the SETUP, SPEED, and COUNT messages and the default value of 6096, which is the nominal pulse count for the radar ground speed sensor. A smaller number, typically 3100, results with a reluctance ground speed sensor.

To perform the Distance Calibration:

### STEP 1

Carefully measure a 400 foot (122 meter) course, plainly marking the start and finish points.

## STEP 2

With the tractor moving between 2 and 5 MPH (3.2 and 8 Km/h), press the START STOP RESET switch when the tractor is exactly even with the start marker. The display showing the Distance Calibration constant zeroes, then counts the ground speed pulses.

## STEP 3

When even with the finish marker, press the START STOP RESET switch.

## STEP 4

To ensure best accuracy, perform this procedure at least three (3) times. Record the count each time, then enter the average as the Distance Calibration constant, using the SELECT and SET switches.

*Figure 15*

*Automatic Configuration Display*



## 8. AUTOMATIC CONFIGURATION

To begin the Automatic Configuration press the START STOP RESET switch. The TEST message flashes while the Automatic Configuration is running. Configuration is complete when the TEST message disappears. The Automatic Configuration will automatically detect how many Seed Modules are connected to the system, how many Seed Sensors are connected to each Module, how many Hopper Sensors are connected in the system, and how many Pressure Sensors are connected in the system.

Note: Fan Speed Sensors and Shaft Speed Sensors are not automatically configured and will need to be setup manually by the user. When Automatic Configuration is run, the number of seed modules, number of seed sensors, number of hopper sensors, and number of pressure sensors is configured to be whatever the results of Automatic Configuration detects in the system. Verify the detected configuration by reviewing the setup constants for the number of seed modules, number of seed sensors, number of hopper sensors, and number of pressure sensors before beginning operation of the implement. Figure 15 shows the Automatic Configuration screen.

### 9. SPLIT ROW CONFIGURATION

For users that utilize split, twin, or skip row type seeding implements, this feature will allow easy configuration for setting up the correct row pattern that is used. Reference Figure 16 for a listing of all of the row patterns that can be applied to the system. When a row pattern is selected all of the rows are automatically turned ON or OFF according to the pattern. The user can still edit individual rows in the Row Configuration Screen, but that must be done after a pattern is selected. Figure 17 shows a row pattern of 01 being selected.

*Figure 16*  
*Split Row Configuration*

Split Row Configuration	Description/Example
00	All Rows On
01	Every other Row Off, with first Row On (OXOXOX)
02	Every other Row Off with first Row Off (XOXOXO)
03	Every Third Row On (OXXOXXOXX)
04	Every Third Row On (XXOXXOXXO)
05	Every Third Row On (XOXXOXXOXX)
06	Every Third Row Off (OOXOOXOOX)
07	Every Third Row Off (OXOOXOOXO)
08	Every Third Row Off (XOOXOOXOO)
09	Every Fourth Row On (OXXXOXXXOXXX)
10	Every Fourth Row On (XXXOXXXOXXXO)
11	Every Fourth Row On (XXOXXXOXXXOXXX)
12	Every Fourth Row On (XOXXXOXXXOXXX)
13	Twin Rows (OOXXOOXXOOXX)
14	Twin Rows (OXXOOXXOOXXOO)
15	Twin Rows (XXOOXXOOXXOO)
16	Twin Rows (XOOXXOOXXOOXX)
17	Every Fourth Row off (OOOXOOOXOOOX)
18	Every Fourth Row Off (OOXOOOXOOOXOOO)
19	Every Fourth Row Off (OXOOOXOOOXOOO)
20	Every Fourth Row Off (XOOOXOOOXOOO)

*Figure 17*  
*Pattern Select Display*

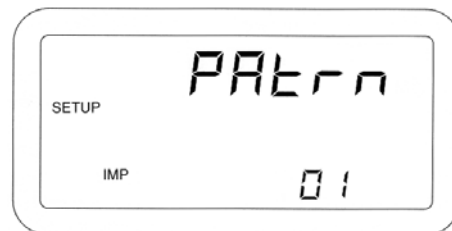

*Figure 18*  
*Seed Modules Display*

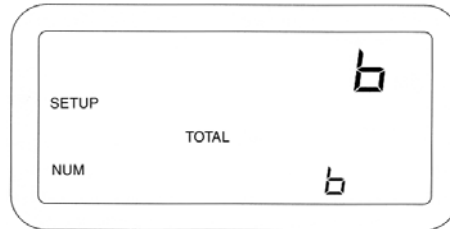

## 10. NUMBER OF SEED MODULES

This is the actual number of Seed Modules that are connected to the system. Note: This does not include the Shaft Speed Module if one is available on the system. This parameter will be checked as part of the Sensor/Module Self-Test and Error codes will be generated if this value does not match the actual number of Seed Modules. Figure 18 shows a configuration for six (6) modules.

*Figure 19*  
*Sensors Per Module Display*

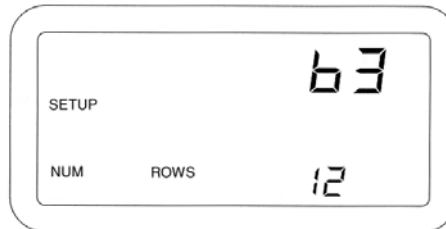

### 10A-E. Number of Seed Sensors Per Module

For each Seed Module that is configured on the previous Setup Screen, there will be a Number of Seed Sensors Per Module screen. This is the actual number of Seed Sensors that are connected to the particular Module. The Modules are Numbered from the far left of the implement (end of P1) to the far right of the implement (end of P2). This parameter will be checked as part of the Sensor/Module Self-Test and Error codes will be generated if this value does not match the actual number of Seed Sensors. Figure 19 shows twelve (12) seed sensors configured on Module 3.

*Figure 20*  
*Row Status Display*

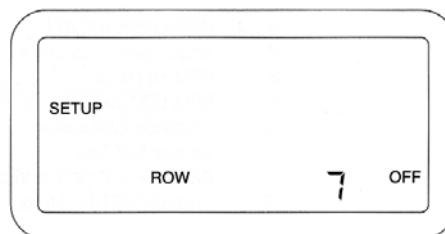

## 11. ROW STATUS

This parameter allows placing individual seed sensors in ON or OFF status. For those situations where it is necessary to turn off certain rows on the implement, OFF status turns off the related sensors so alarms do not occur.

The display initially shows the messages SETUP, ROW, 1, and the status of row 1. Figure 20 shows row 7 status set to OFF. Press the SET switch to toggle between ON and OFF for the Standard and Hi-Rate seed sensors. Press the SELECT ROW switch to advance to the next row. When the status of all rows is correctly entered, press SETUP to advance to the next Setup constant.

*Figure 21*  
*Rows Configured Display*

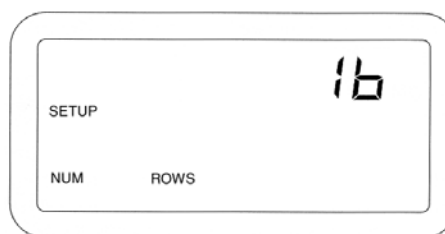

## 12. TOTAL NUMBER OF ROWS CONFIGURED

This parameter is used to calculate Implement Width and is used in checking the number of seed sensors detected upon system power up. This value is displayed for confirmation only and can only be altered by changing the Number of Seed Modules or Number of Seed Sensors Per Module parameters. Figure 21 shows the display for sixteen (16) rows.

*Figure 22*  
*Fan Speed Sensor Display*



### **13. NUMBER OF FAN SPEED SENSORS**

This is the actual number of Fan Speed Sensors that are connected to a Shaft Speed Module on the system. For each Fan Speed Sensor that is configured here there will be an operate screen generated. Fan Speed Sensors are not Self-Tested and will not generate any error codes except for operational error codes for Hi and Lo Limit warnings. Figure 22 shows a configuration of two (2) Fan Speed Sensors.

*Figure 23*  
*Fan Speed Constant Display*

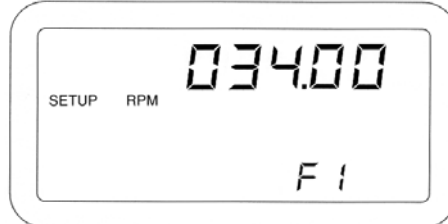

#### **13A and 13D. Fan Speed Sensor Constant**

The Fan Speed Constant is the number of pulses the Fan Speed Sensor generates in one revolution of the monitored fan. This is typically the number of teeth (sense points) on the fan. The Fan Speed Constant can be entered as a decimal with 0.01 resolution. Entering a value of zero (000.00) disables the Fan Speed function. The Fan Speed Sensor Constant is accessible only if the Number of Fan Speed Sensors has a value other than 0. Figure 23 shows the display with a Fan Speed Constant of 34.00 pulses per revolution.

*Figure 24*

*Hi Limit Fan Speed Display*

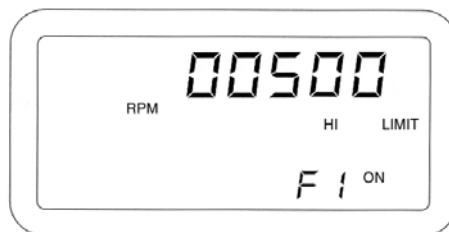

### **13B and 13E. Fan Speed Sensor Hi Limit**

This constant is the highest Fan Speed (RPM) allowed before sounding a warning alarm. The Hi and Lo warning limits are accessible only if the Number of Fan Speed Sensors has a value other than 0. The warning is enabled or disabled by selecting the ON or OFF message. Use the SELECT switch to advance one step to the right of the right most digit, then press the SET switch to toggle between ON and OFF. Figure 24 shows a limit of 500 RPM with the warning enabled.

*Figure 25*

*Lo Limit Fan Speed Display*

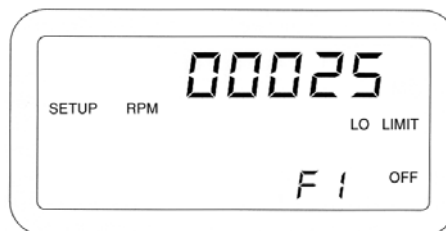

### **13C and 13F. Fan Speed Sensor Lo Limit**

This constant is the lowest Fan Speed (RPM) allowed before sounding a warning alarm. The Hi and Lo warning limits are accessible only if the Number of Fan Speed Sensors has a value other than 0. The warning is enabled or disabled by selecting the ON or OFF message. Use the SELECT switch to advance one step to the right of the right most digit, then press the SET switch to toggle between ON and OFF. Figure 25 shows a limit of 25 RPM with the warning disabled.

*Figure 26*

*Shaft Speed Sensor Display*



## **14. NUMBER OF SHAFT SPEED SENSORS**

This is the actual number of Shaft Speed Sensors that are connected to a Shaft Speed Module on the system. For each Shaft Speed Sensor that is configured here there will be an operate screen generated. Shaft Speed Sensors are not Self-Tested and will not generate any error codes except for operational error codes for Hi and Lo Limit warnings. Figure 26 shows a configuration of three (3) Shaft Speed Sensors.

*Figure 27*

*Shaft Speed Constant Display*



### **14A, 14D, and 14G. Shaft Speed Sensor Constant**

The Shaft Speed Constant is the number of pulses the Shaft Speed Sensor generates in one revolution of the monitored shaft. This is typically the number of teeth (sense points) on the gear attached to the monitored shaft. The Shaft Speed Constant can be entered as a decimal with 0.01 resolution. Entering a value of zero (000.00) disables the Shaft Speed function. The Shaft Speed Sensor Constant is accessible only if the Number of Shaft Speed Sensors has a value other than 0. Figure 27 shows the display with a Shaft Speed Constant of 26.00 pulses per revolution.

*Figure 28*

*Hi Limit Shaft Speed Display*

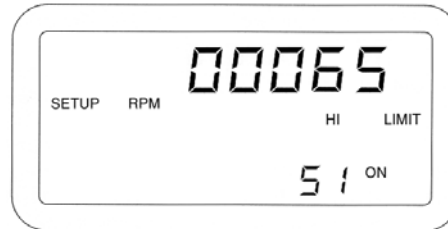

### **14B, 14E, and 14H. Shaft Speed Sensor Hi Limit**

This constant is the highest Shaft Speed (RPM) allowed before sounding a warning alarm. The Hi and Lo warning limits are accessible only if the Number of Shaft Speed Sensors has a value other than 0. The warning is enabled or disabled by selecting the ON or OFF message. Use the SELECT switch to advance one step to the right of the right most digit, then press the SET switch to toggle between ON and OFF. Figure 28 shows a limit of 65 RPM with the warning enabled.

*Figure 29*

*Lo Limit Shaft Speed Display*

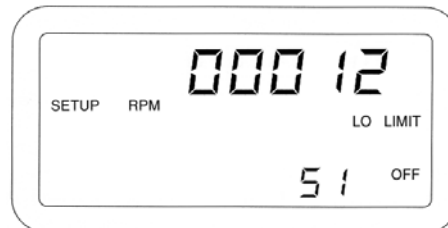

### **14C, 14F and 14I. Shaft Speed Sensor Lo Limit**

This constant is the lowest Shaft Speed (RPM) allowed before sounding a warning alarm. The Hi and Lo warning limits are accessible only if the Number of Shaft Speed Sensors has a value other than 0. The warning is enabled or disabled by selecting the ON or OFF message. Use the SELECT switch to advance one step to the right of the right most digit, then press the SET switch to toggle between ON and OFF. Figure 29 shows a limit of 12 RPM with the warning disabled.

*Figure 30*  
*Hopper Level Display*



## 15. NUMBER OF HOPPER LEVEL SENSORS

This is the actual number of Hopper Level Sensors that are connected to all modules in the system. This parameter will be checked as part of the Sensor/Module Self-Test and Error codes will be generated if this value does not match the actual number of Hopper Level Sensors. Figure 30 shows a configuration of five (5) Hopper Sensors.

*Figure 31*  
*Pressure Sensor Display*

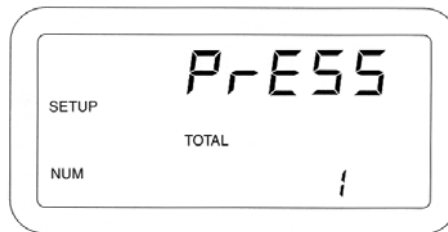

## 16. NUMBER OF PRESSURE SENSORS

This is the actual number of Pressure Sensors that are connected to a Shaft Speed Module on the system. This parameter will be checked as part of the Sensor/Module Self-Test and Error codes will be generated if this value does not match the actual number of Pressure Sensors. Figure 31 shows a configuration of one (1) Pressure Sensor.

*Figure 32*

*Hi Limit Pressure Display*



### **16A and 16C. Pressure Sensor Hi Limit**

The Pressure Sensor Hi Limit Warning is entered in oz/in<sup>2</sup> (kPa). The Hi and Lo warning limits are accessible only if the Number of Pressure Sensors has a value other than 0. Setting the Pressure Sensor Hi Limit will cause the audible alarm to sound when the pressure exceeds the value that has been entered. Use the SET and SELECT switches to adjust the Pressure Sensor Hi Limit value. The Pressure Sensor Hi Limit can be enabled or disabled by selecting the ON or OFF symbol after the rightmost digit. Pressing the SET switch will toggle the status of the warning between ON and OFF. Figure 32 shows a Pressure Sensor Hi Limit of 18.0 with the warning enabled.

*Figure 33*

*Lo Limit Pressure Display*

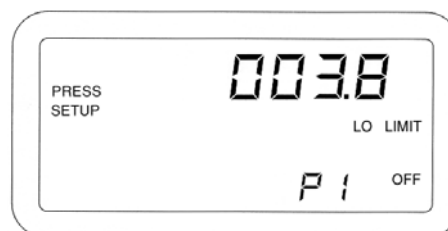

### **16B and 16D. Pressure Sensor Lo Limit**

The Pressure Sensor Lo Limit Warning is entered in oz/in<sup>2</sup> (kPa). The Hi and Lo warning limits are accessible only if the Number of Pressure Sensors has a value other than 0. Setting the Pressure Sensor Lo Limit will cause the audible alarm to sound when the pressure falls below the value that has been entered. Use the SET and SELECT switches to adjust the Pressure Sensor Lo Limit value. The Pressure Sensor Lo Limit can be enabled or disabled by selecting the ON or OFF symbol after the rightmost digit. Pressing the SET switch will toggle the status of the warning between ON and OFF. Figure 33 shows a Pressure Sensor Lo Limit of 3.8 with the warning disabled.

*Figure 34*  
*Blockage Configuration*

Blockage Mode	Description
0	All Rows are configured for displaying Population
1	First Row of each Module is configured for displaying Population- All other rows are configured for Blockage Only
2	All Rows are configured for Blockage Only

*Figure 35*  
*Blockage Mode Display*



## 17. BLOCKAGE MODE CONFIGURATION

This configuration will select one of three different modes according to the Table in Figure 34. If Mode 0 or Mode 1 is selected, the Operate screens will cycle through the Population Rows only. If Mode 2 is selected, the Population and Spacing Operate screens will show a series of 5 dashes to represent no data. In all modes, row failures will be displayed according to the details in the ALARMS section of this document. Figure 35 shows a Blockage Mode Configuration of 0.

*Figure 36*  
*Population Filter Display*

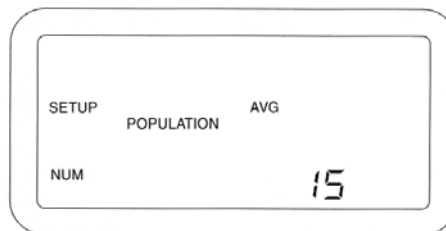

## 18. POPULATION FILTER

In certain applications the Seed Manager<sup>®</sup> SE, due to its rapid update rate, might exhibit fluctuations in population and spacing that are undesirable to the operator. The population filtering option applies an averaging filter to the population and spacing calculations. The filter values range from 0 to 99, with 0 having no filtering effect, and 99 being the maximum filtering value. Use the SET and SELECT switches to adjust the filtering value. Figure 36 shows a Population Filter of 15.

*Figure 37*

*Population Scaling Display*

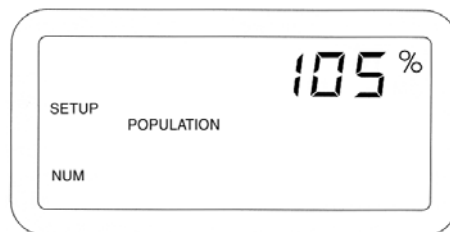

## 19. POPULATION SCALING FACTOR

The population scaling factor allows the operator to make fine adjustments in the readout of population and spacing on a percentage basis. This value is adjustable from 1% to 999% with the factory default being 100%. Use the SET and SELECT switches to adjust to the desired population scaling factor. Figure 37 shows a Population Scalar of 105%.

*Figure 38*

*Sensor Self Test Display*

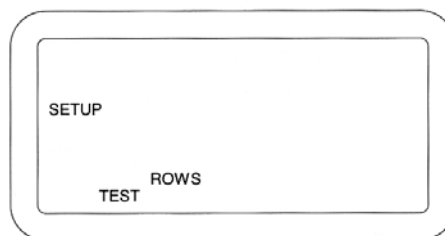

## 20. SENSOR/MODULE SELF-TEST

Start the test by pressing the START STOP RESET switch. The TEST message flashes while the test is executing (Note: This is the same test that is performed automatically during console power up). When the test is complete the display will show either PASSED (and scroll through all available seed rows), or show FAILED and display the appropriate error code(s). If multiple errors exist, the E in the error code will be flashing. To view the next error code, press the Alarm switch. For a full description of all the error codes and their meanings, see the ERROR CODES chapter. Figure 38 shows the Sensor/Module Self Test Screen.

*Figure 39*

*Units Selection Display*

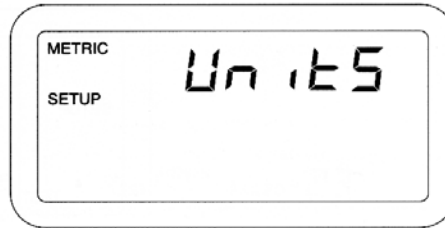

## 21. ENGLISH/METRIC UNITS

The user selects the system of units with this constant. The SET switch is used to toggle between English and Metric units. Figure 39 shows the display when Metric units are selected. The METRIC message is absent when English units are selected.

## CUSTOMER SETUP CONSTANTS

The Customer Setup Constants are entered by holding the SETUP switch depressed while powering on the console and continuing to hold it depressed until the Display Test begins. A flashing SETUP message indicates the console is in the Customer Setup Constants. Press the SETUP switch to advance to the next Customer Setup Constant. To exit the Customer Setup Constants, power off the console. The different Customer Setup Constants are listed as follows:

*Figure 40*

*Boot Number Display*

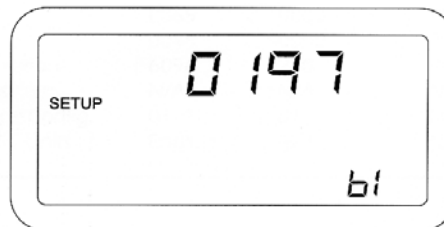

### 1. Boot Version Number

DICKEY-john's Service Department may request the customer to observe and record the four (4) different 4-digit numbers (to identify the "boot memory" software version) in the unlikely event field problems occur.

The first 4-digit number shows on the upper numeric display at the same time a "b1" identifier appears on the lower numeric display. Record this number, then press and release the SELECT switch to step to the "b2", "b3", and "bc" numbers, recording each 4-digit number along with its

identifier. To return to “b1” again press the SELECT switch. Press SETUP to advance to the next constant. Figure 40 shows “0197” for “b1”, the first Boot Version Number.

*Figure 41*

*Flash Version Number Display*

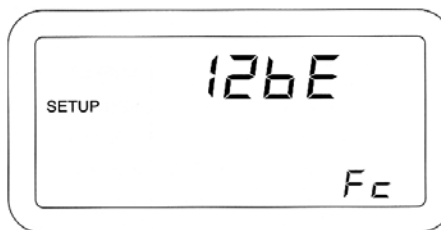

## **2. Flash Version Number**

DICKEY-john's Service Department may request the customer to observe and record the four (4) different 4-digit numbers (to identify the “flash memory” software version) in the unlikely event field problems occur.

The first 4-digit number shows on the upper numeric display at the same time a “F1” identifier appears on the lower numeric display. Record this number, then press and release the SELECT switch to step to the “F2”, “F3”, and “Fc” numbers, recording each 4-digit number along with its identifier. To return to “F1” again press the SELECT switch. Press SETUP to advance to the next constant. Figure 41 shows “126E” for “Fc”, the first Boot Version Number.



## OPERATION

### OPERATE MODE

Performance of the following Operate Mode functions assumes the console has been properly installed and setup as detailed in the INSTALLATION and SETUP MODE chapters respectively. Figure 42 lists all Operate Mode functions and shows which are available in the Speed Area Mode (defined later in this chapter). Notice this list includes all the function names on the three (3) Operate Mode switches, plus the Run Hours function which is performed automatically.

*Figure 42*

<b>Operate Mode Function Name</b>	<b>Available in Speed Area Mode</b>
Run Hours	Yes
Population	No
Seed Spacing	No
Ground Speed	Yes
Fan Speed	Yes
Shaft Speed	Yes
Pressure	Yes
Area Accumulator	Yes
Seed Count	No
Distance Accumulator	Yes

*Figure 43*

*Run Hours Display*

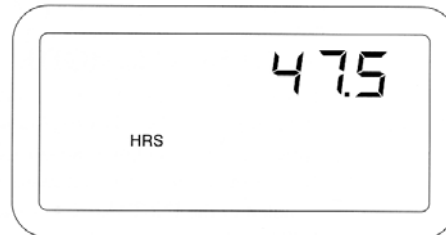

### RUN HOURS

This is defined as the total number of accumulated hours, in 0.1 hour increments, the console has been powered. Run Hours are not accumulated during an ALL ROWS FAILED condition or if a lift switch is installed and the implement is in the up position. The Run Hours total is displayed for five (5) seconds immediately following the power up sequence. The SETUP switch or any of the three Operate Mode switches can be pressed during the display of the Run Hours to advance immediately to the desired function. Otherwise the Population function is automatically selected. To zero the accumulated Run Hours, press the START STOP RESET switch for one (1) second while Run Hours are displayed. Figure 43 shows Run Hours of 47.5.

## POPULATION

This is the amount of seeds, in thousands of seeds per acre (hectare), shown in a given row, based upon the most recent sampling of the seeding rate for that row. The Population function is selected automatically on power up or by pressing the OPERATE 1 switch until the POPULATION message appears on the display. Only the seed rows that have their row status set to ON will be displayed in the Population function. If the Blockage Mode is set to All Rows Blockage, the upper numeric display will show a series of five (5) dashes and no population values will be available. The Population display has several different modes based upon the Setup configuration and the scan mode that is selected. A short description of each mode is described below.

*Figure 44*

*Population Scan Display*

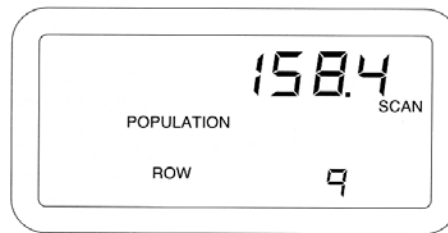

## POPULATION SCAN

This mode will display the population of each valid row for two (2) seconds, then advances to the next row. After the last row population is displayed, the average seeding population (for all valid population rows) is displayed, identified by the AVG message. Population Scan mode is selected automatically upon powerup or by pressing the MIN AVG MAX SCAN switch until the SCAN message is displayed while in Population function. Figure 44 shows a population of 158,400 seeds/acre on row nine (9) while in Population Scan.

*Figure 45*

*Population Min-Avg-Max Display*

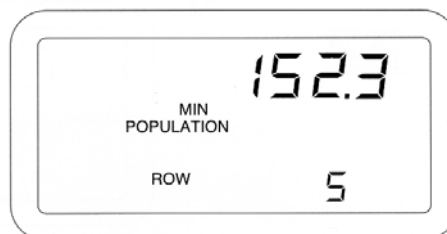

## **POPULATION MIN AVG MAX**

This mode will display the seeding row with the minimum population, the average seeding population, and the seeding row with the maximum population in cyclic fashion, dwelling on each for three (3) seconds. This option is selected by pressing the MIN AVG MAX SCAN switch while in the Population function. Figure 45 shows a minimum population of 152,300 seeds/acre on row five (5).

*Figure 46*

*Population Select Row Display*

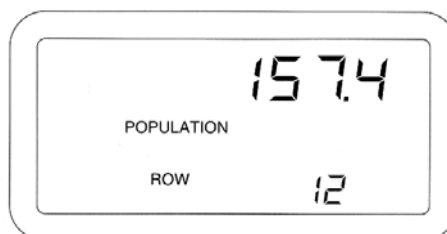

## **POPULATION SELECT ROW**

Depressing the SELECT ROW switch while in either Population Scan or Population Min Avg Max freezes the population display on the current row or the implement average. Pressing the SELECT ROW switch again causes the display to advance to the next valid population row. Pressing the BACK switch will cause the display to return to the previous valid population row. Figure 46 shows a population of 157,400 seeds/acre on row twelve (12) while in Population Select Row.

*Figure 47*

*Seed Spacing Average Display*

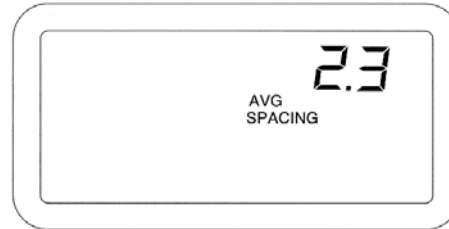

## **SEED SPACING**

This is the calculated average spacing between seeds in the furrow, in inches (centimeters). The resolution is in 0.1 inches (centimeters). This function is selected by pressing the OPERATE 1 switch until the SPACING message appears on the display. The Seed Spacing display has several different modes based upon the Setup configuration and the scan mode that is selected, and they are the same modes as in the Population function. Figure 47 shows an implement average seed spacing of 2.3 inches between seeds.

*Figure 48*

*Ground Speed Display*

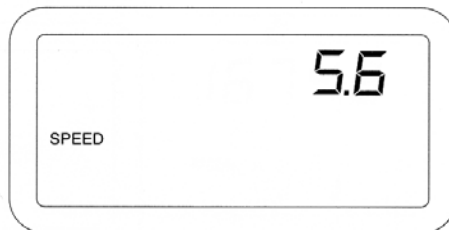

## **GROUND SPEED**

This is the ground speed in MPH (Km/h), with 0.1 resolution, as measured by the ground speed sensor. This function is selected by pressing the OPERATE 1 switch until the SPEED message appears on the display. The ground speed sensor can be either radar, Hall Effect, or reluctance type. Figure 48 shows a ground speed of 5.6 MPH.

*Figure 49*  
*Fan Speed Display*

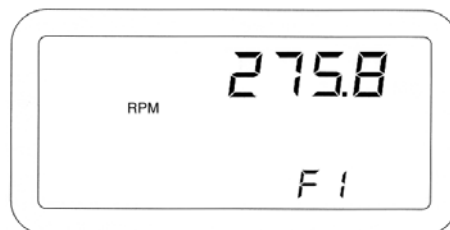

## **FAN SPEED**

This is the rotational speed of any Fan the user wishes to monitor. A Hall Effect type sensor senses points on a fan to a resolution of 0.1 RPM. This function is selected by pressing the OPERATE 2 switch until "F1" or "F2" is displayed in the lower numerical display. Figure 49 shows a fan speed of 275.8 RPM.

*Figure 50*  
*Shaft Speed Display*

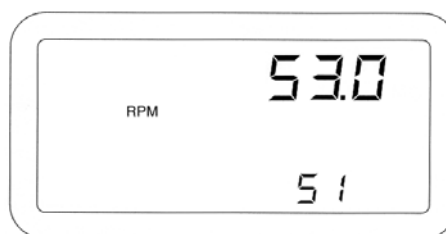

## **SHAFT SPEED**

This is the rotational speed of any shaft the user wishes to monitor. A Hall Effect type sensor senses a multi-toothed gear mounted on the shaft, to a resolution of 0.1 RPM. Typically a shaft driving the seeding mechanism is monitored. This function is selected by pressing the OPERATE 2 switch until "S1", "S2", or "S3" is displayed in the lower numerical display. Figure 50 shows a shaft speed of 53.0 RPM.

*Figure 51*  
*Pressure Display*

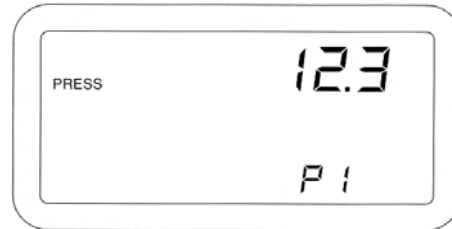

## **PRESSURE**

This is the pressure in oz/in<sup>2</sup> (kPa), as measured by a pressure sensor, to a resolution of 0.1 oz/in<sup>2</sup> (kPa). This function is selected by pressing the OPERATE 2 switch until "P1" or "P2" is displayed in the lower numerical display. Figure 51 shows a pressure of 12.3 oz/in<sup>2</sup>.

*Figure 52*  
*Area Accumulator 1 Display*



## **AREA ACCUMULATOR**

Area Accumulator 1 and 2 is intended to be used as a field area accumulator, displaying acres with 0.1 resolution (hectares with 0.01 resolution). Area Accumulator 3 is intended to be used as a total area accumulator with the same resolution as Area Accumulator 1 and 2. The area calculations are based on the Implement Width and distance traveled. Area does not accumulate during an ALL ROWS FAILED condition, i. e., when the implement is raised. This function is selected by pressing the OPERATE 3 switch until the AREA message appears and a "1", "2", or "3" is shown in the lower right corner of the display. Area Accumulator 1 and 2 is reset by pressing the START STOP RESET switch for at least one (1) second. When a total of 9999.9 acres (999.99 hectares) is exceeded, the decimal point shifts to the right one place. When a total area of 99999 acres (hectares) is exceeded, it will roll over to zero (0). Figure 52 shows Area Accumulator 1 with 1674.3 acres. Area Accumulator 3 is not resettable.

*Figure 53*  
*Seed Count Display*

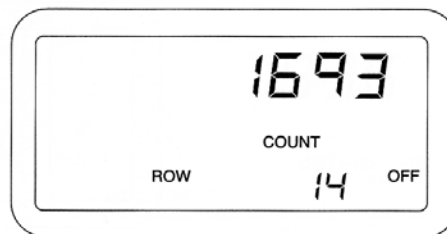

## SEED COUNT

This function is used to count the number of seeds passing through each seed sensor. This function is selected by pressing the OPERATE 3 switch until the COUNT message appears.

Press the START STOP RESET switch to start the measurement, then press it again to stop. The ON and OFF messages on the display indicate the Seed Count function status. To zero the accumulated seed count on the selected row, press and hold the START STOP RESET switch until a beep occurs (approximately one (1) second). To zero the seed count for all rows, press and hold the START STOP RESET switch for at least three (3) seconds. When a total of 99999 counts is exceeded, the count rolls over to zero (0). Depress the SELECT ROW switch to advance the display to the next row. Depress the BACK switch to return to the previous row.

Any other Operate Mode function can be selected while Seed Count is running without affecting the actual seed counts. Figure 53 shows a stopped seed counter with 1693 seeds counted on row fourteen (14).

*Figure 54*  
*Distance Accumulator Display*

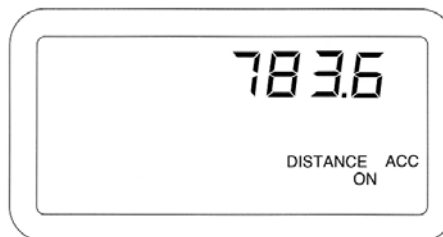

## DISTANCE ACCUMULATOR

This function is used to measure distances in feet (meters), with 0.1 resolution. It can only be used after the Distance Calibration Constant has been accurately established (See the SETUP MODE chapter for details).

This function is selected by pressing the OPERATE 3 switch until the DISTANCE and ACC messages appear on the display.

Press the START STOP RESET switch to start the measurement, then press it again to stop. The ON and OFF messages on the display indicate the Distance Accumulator function status. To zero the distance accumulator, press and hold the START STOP RESET switch until a beep occurs (approximately one (1) second). When a total of 9999.9 feet (meters) is exceeded the accumulator rolls over to zero (0).

Any other Operate Mode function can be selected while Distance Accumulator is running without affecting the actual distance accumulation. Figure 54 shows a running distance accumulator with 783.6 feet measured.

## **SPEED AREA MODE**

The Speed Area Mode is used to monitor non-seeding operations like cultivating. Only the Speed, Fan Speed, Shaft Speed, Pressure, Area, and Distance Accumulator functions are available in this mode. Figure 42 shows this function availability in chart form. The console display for these functions is identical in the Speed Area and Operate Modes.

Enter the Speed Area Mode as follows:

1. A lift switch (Implement status switch) must be connected to a Shaft Speed Module that is connected to the system, and no seed sensors can be connected.
2. Power down, wait a minimum of 10 seconds before re-powering the system, then power up the console.
3. The alarm will sound momentarily and an E00 (No seed sensors connected) error code will be displayed. Press the OPERATE 2 or OPERATE 3 switch, depending on which Speed Area Mode function is desired.

To accumulate area in the Speed Area Mode, the lift switch must indicate the implement is down. Run Hours accumulate only when the implement is down. The Distance Accumulator function is independent of the lift switch status.

## ALARMS

Priority levels are assigned to the Seed Manager<sup>®</sup> SE alarms as shown in Figure 55, with level one (1) being the highest. If two alarm conditions are detected at the same time, only the higher priority alarm is displayed. If they are the same level, both are displayed simultaneously.

**NOTE:** A Row Failure Alarm will acknowledge the audible alarm only and will not clear the display. To clear a Row Failure Alarm the condition must be fixed, or the row must be turned OFF in SETUP MODE.

Unless indicated below, when an alarm condition occurs, the console exits the current Operate Mode function to display the alarm. It returns to that Operate Mode function only after the alarm condition ceases or the ALARM switch has been pressed to acknowledge the alarm condition (except for a Row Failure Alarm).

A “warning” alarm is accompanied by a beeping sound lasting for a fixed time period related to its priority. The higher the priority, the longer the alarm is sounded. Unless otherwise indicated, a “failure” alarm sounds continuously (not beeping) until the failure condition ceases or is acknowledged by pressing the ALARM switch.

*Figure 55*

*Alarm Levels*

<b>Alarm Mode</b>	<b>Priority Level</b>
All Rows Failed	1
Row Failed	2
Distance Sensor Failed	3
Population Hi Limit Warning	4
Population Lo Limit Warning	4
Fan Speed Hi Limit Warning	5
Fan Speed Lo Limit Warning	5
Shaft Speed Hi Limit Warning	6
Shaft Speed Lo Limit Warning	6
Pressure Hi Limit Warning	7
Pressure Lo Limit Warning	7
Hopper Lo Warning	8
Battery Voltage Warning	9

### ALL ROWS FAILED

This occurs at the end of each row when the implement is lifted from the ground. The alarm sounds continuously for three (3) seconds, the ROWS and FAILED messages appear, and the row numbers are displayed sequentially. After the alarm silences, the console reverts to the previous Operate Mode function.

## ROWS FAILED

This occurs when two (2) seeds per second or less are detected. The alarm sounds continuously and the row number of the failed sensor appears with the messages ROW and FAILED. If multiple rows fail, the numbers of the failed rows are sequentially displayed at the rate of one per second. This alarm can be acknowledged by pressing the ALARM switch. This will silence the audible alarm, but the display will remain until the condition ceases, or the user enters the SETUP MODE Row Status and turns the faulty rows to the OFF status. After the audible alarm is acknowledged, the only functions that are available are in the SETUP MODE (reference the SETUP MODE chapter for more information).

*Figure 56*

*Distance Sensor Failed Display*

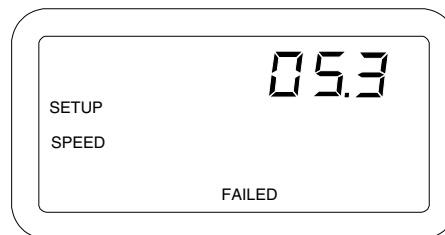

## DISTANCE SENSOR FAILED

If seed flow is detected without a signal from the ground speed sensor and the monitor is not in Seed Count function for a duration of thirty (30) seconds, the alarm sounds continuously for five (5) seconds and the console automatically enters a mode to manually enter a ground speed value. A manual (simulated) ground speed value, in MPH (Km/h), appears on the display along with the SETUP, SPEED, and FAILED messages.

To continue in the Operate Mode without a functioning ground speed sensor, the operator must first enter a suitable manual ground speed value using the SELECT and SET switches. Figure 56 shows the above mentioned Setup display with a manual ground speed of 5.3 MPH entered. The operator next presses the desired Operate Mode switch to return to seeding.

*NOTE: It is important to maintain ground speed close to the manually entered value to ensure accurate monitoring.*

The console will continue to use this manual ground speed until the console is next powered off, or the ground speed sensor signal begins to function again. If the damaged ground speed sensor or cable cannot be repaired or replaced before it is desired to continue seeding, the same alarm display will reappear each time power is applied to the console, with the manual ground speed value last entered being retained. Again, operation can continue by pressing the switch for the desired Operate Mode.

When the ground speed sensor has been properly repaired or replaced, normal operation will automatically resume without having to deactivate the manual ground speed. However, it is very important to remember to immediately repeat the SETUP MODE Distance Calibration before resuming operation if a different ground speed sensor has been installed. Otherwise, the previously determined Distance Calibration Constant will be used, possibly resulting in ground speed measurement errors which may not be readily detected. Ground speed sensor cable only repairs do not require recalibration.

*Figure 57*

*Population Hi Limit Warning Display*

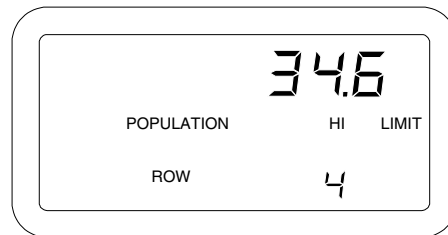

## POPULATION HI LIMIT WARNING

This occurs when any row population exceeds the value entered for Population Hi Limit in the SETUP MODE. The alarm beeps for four (4) seconds and the row number and actual population, in thousands of seeds per acre (hectare), are displayed. If multiple rows exceed the limit, the row numbers are displayed sequentially, along with their respective populations. Figure 57 shows a Population Hi Limit Warning on row four (4) with a row population of 34,600 seeds per acre.

*Figure 58*

*Population Lo Limit Warning Display*

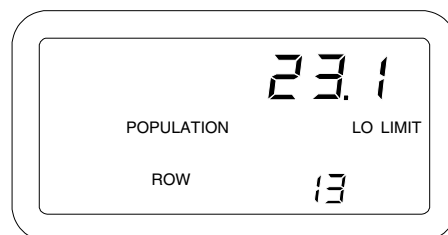

## POPULATION LO LIMIT WARNING

This occurs when any row population falls below the value entered for Population Lo Limit in the SETUP MODE. The alarm beeps for four (4) seconds and the row number and actual population, in thousands of seeds per acre (hectare), are displayed. If multiple rows fall below the limit, the

row numbers are displayed sequentially, along with their respective populations. Figure 58 shows a Population Lo Limit Warning on row thirteen (13) with a row population of 23,100 seeds per acre.

*Figure 59*

*Fan Speed Hi Limit Warning Display*

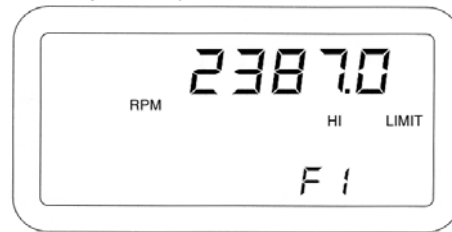

## FAN SPEED HI LIMIT WARNING

This occurs when any fan speed exceeds the value entered for Fan Speed Hi Limit in the SETUP MODE. The alarm beeps for three (3) seconds and the fan speed sensor number and actual fan speed, in RPM, are displayed. If multiple fan speed sensors exceed the limit, the fan speed sensor numbers are displayed sequentially, along with their respective fan speeds. Figure 59 shows a Fan Speed Hi Limit Warning on fan speed sensor one (1) with a fan speed of 2,387 RPM.

*Figure 60*

*Fan Speed Lo Limit Warning Display*

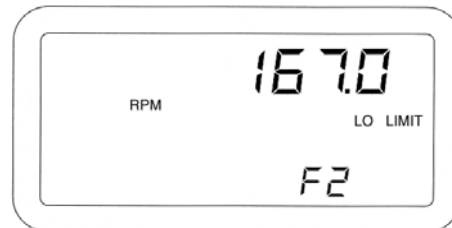

## FAN SPEED LO LIMIT WARNING

This occurs when any fan speed falls below the value entered for Fan Speed Lo Limit in the SETUP MODE. The alarm beeps for three (3) seconds and the fan speed sensor number and actual fan speed, in RPM, are displayed. If multiple fan speed sensors fall below the limit, the fan speed sensor numbers are displayed sequentially, along with their respective fan speeds. Figure 60 shows a Fan Speed Lo Limit Warning on fan speed sensor two (2) with a fan speed of 167 RPM.

*Figure 61*

*Shaft Speed Hi Limit Warning Display*

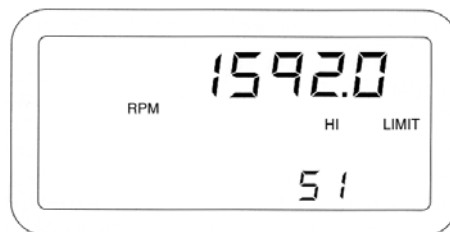

## **SHAFT SPEED HI LIMIT WARNING**

This occurs when any shaft speed exceeds the value entered for Shaft Speed Hi Limit in the SETUP MODE. The alarm beeps for three (3) seconds and the shaft speed sensor number and actual shaft speed, in RPM, are displayed. If multiple shaft speed sensors exceed the limit, the shaft speed sensor numbers are displayed sequentially, along with their respective shaft speeds. Figure 61 shows a Shaft Speed Hi Limit Warning on shaft speed sensor one (1) with a shaft speed of 1,592 RPM.

*Figure 62*

*Shaft Speed Lo Limit Warning Display*

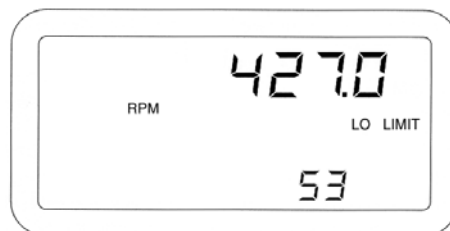

## **SHAFT SPEED LO LIMIT WARNING**

This occurs when any shaft speed falls below the value entered for Shaft Speed Lo Limit in the SETUP MODE. The alarm beeps for three (3) seconds and the shaft speed sensor number and actual shaft speed, in RPM, are displayed. If multiple shaft speed sensors fall below the limit, the shaft speed sensor numbers are displayed sequentially, along with their respective shaft speeds. Figure 62 shows a Shaft Speed Lo Limit Warning on shaft speed sensor three (3) with a shaft speed of 427 RPM.

*Figure 63*

*Pressure Hi Limit Warning Display*

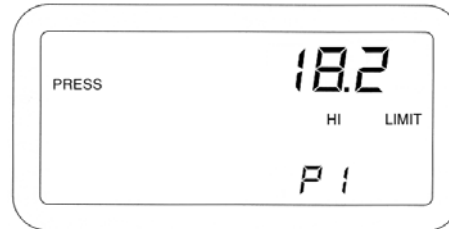

## **PRESSURE HI LIMIT WARNING**

This occurs when any pressure input exceeds the value entered for Pressure Hi Limit in the SETUP MODE. The alarm beeps for three (3) seconds and the pressure sensor number and actual pressure, in oz/in<sup>2</sup> (kPa), are displayed. If multiple pressure sensors exceed the limit, the pressure sensor numbers are displayed sequentially, along with their respective pressures. Figure 63 shows a Pressure Hi Limit Warning on pressure sensor one (1) with a pressure of 18.2 oz/in<sup>2</sup>.

*Figure 64*

*Pressure Lo Limit Warning Display*

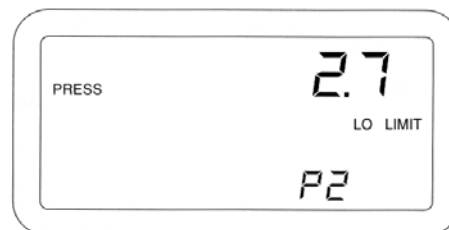

## **PRESSURE LO LIMIT WARNING**

This occurs when any pressure input falls below the value entered for Pressure Lo Limit in the SETUP MODE. The alarm beeps for three (3) seconds and the pressure sensor number and actual pressure, in oz/in<sup>2</sup> (kPa), are displayed. If multiple pressure sensors fall below the limit, the pressure sensor numbers are displayed sequentially, along with their respective pressures. Figure 64 shows a Pressure Lo Limit Warning on pressure sensor two (2) with a pressure of 2.7 oz/in<sup>2</sup>.

*Figure 65*

*Hopper Lo Warning Display*

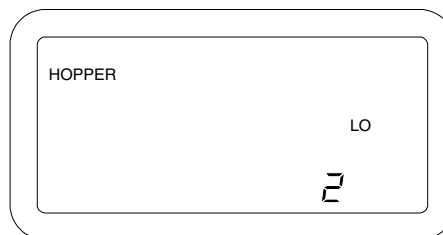

## **HOPPER LO WARNING**

This occurs when any hopper input signals a low material level. The alarm sounds continuously and the hopper sensor number is displayed along with the HOPPER and LO messages. If multiple hopper sensors signal a low material level, the hopper sensor numbers are displayed sequentially. Figure 65 shows a Hopper Lo Warning on hopper two (2).

*Figure 66*

*Battery Voltage Warning Display*

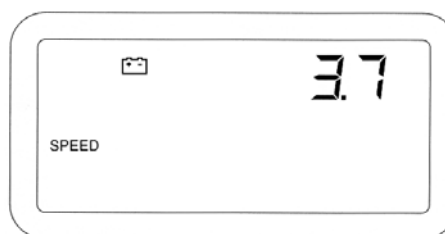

## **BATTERY VOLTAGE WARNING**

To ensure accurate operation of the sensors and modules, the voltage to the console must be at least eleven (11) volts. When the tractor battery voltage falls below this level, regardless of the Operate Mode function, the alarm beeps for three (3) seconds and the battery symbol appears. The battery symbol remains on the display until the low battery condition ceases. The warning beeps reoccur each time the monitor is powered on. Figure 66 shows the battery symbol in the Operate Mode Speed function with a ground speed of 3.7 MPH.



## SELF TEST ERROR CODES

The Seed Manager® SE Console performs a Self Test upon power up and when commanded by the user in SETUP MODE. At the end of the Self Test the console will either show PASSED and cycle through all of the seed rows, or the console will display the appropriate error codes that were detected. Figure 67 shows a complete list of all error codes that can be displayed. See the TROUBLESHOOTING chapter for additional details and recommended recovery procedures.

*Figure 67*

*Self-Test Error Codes*

<b>Error Code</b>	<b>Description</b>
E00	No Modules Connected
E01	Too Many Modules Connected on P1 or P2
E10	Too Few Seed Modules Connected
E11	Too Many Seed Modules Connected
E20	Too Few Shaft Modules Connected
E21	Too Many Shaft Modules Connected
E30X	Too Few Seed Sensors Connected to Module X
E31X	Too Many Seed Sensors Connected to Module X
E40	Too Few Hopper Sensors Connected
E41	Too Many Hopper Sensors Connected
E50	Too Few Pressure Sensors Connected
E51	Too Many Pressure Sensors Connected
E70	Module 8V Power Supply Too Low
E71	Module 8V Power Supply Too High
E98	Internal LCD Driver Failure
E99	Internal Bus Failure



## TROUBLESHOOTING

### MONITOR DEAD

#### Probable Cause

1. Blown console fuse
2. Poor battery connections
3. Cut or broken battery cable
4. Low battery voltage
5. Defective Console

#### Corrective Action

1. Check console fuse. If blown, replace with a five (5) Amp, type AGC fuse. If it blows again, contact DICKEY-john Technical Support to replace console. See inside, back cover of this manual for phone number.
2. Clean and tighten battery connections
3. Repair by splicing, soldering, and individually heatshrinking each wire. Use only Rosin Core Solder.
4. Verify battery voltage is at least twelve (12) volts. If not, recharge or replace battery.
5. Contact DICKEY-john Technical Support. See inside, back cover of this manual for phone number.

### BATTERY SYMBOL APPEARS ON DISPLAY

#### Probable Cause

1. Low battery voltage
2. Intermittent harness short to ground
3. Poor battery connections

#### Corrective Action

1. Recharge or replace battery
2. Locate short and repair by splicing, soldering, and sealing the wire
3. Clean and tighten battery connections

### ERROR CODE E00

No Modules have been detected by the Console.

#### Probable Cause

1. Implement Harness not connected to Tractor Harness
2. Implement Harness not connected to First Module (on P1 or P2 line)
3. Harnessing cut and/or pinched
4. Defective Console or Defective Module

## **Corrective Action**

1. Check tractor harness and implement harness connections
2. Check connection at P1 and bus harness to the first module. Reapply power to the console. If E00 occurs again, the tractor harness, module, or console is defective.
3. Locate the fault and repair wires by splicing, soldering, and sealing wires.
4. Contact DICKEY-john Technical Support. See inside, back cover of this manual for phone number.

## **ERROR CODE E01**

Too Many Modules are connected to either P1 line or P2 line.

### **Probable Cause**

More than Four modules are connected to either P1 or P2 Bus lines on Implement Harness.

### **Corrective Action**

Distribute modules evenly between P1 and P2 bus lines

## **ERROR CODE E10**

Too Few Seed Modules are Connected.

### **Probable Cause**

1. Number of Seed Modules Configuration is incorrect.
2. Implement Harness not connected to all Seed Modules
3. Harnessing cut and/or pinched
4. Defective Module

### **Corrective Action**

1. Check the Number of Seed Modules Configuration in SETUP MODE with the actual number of modules connected.
2. Check harness connection after the module number associated with number in lower display.
3. Locate the fault and repair wires by splicing, soldering, and sealing wires.
4. Exchange module after the module number associated with number in lower display and reapply power to the console. If the same exact error code and lower digit number is displayed then the module number associated with the lower display is defective. If the lower digit changes then the module that was replaced was defective.

## ERROR CODE E11

Too Many Seed Modules are Connected

### **Probable Cause**

Number of Seed Modules Configuration is incorrect

### **Corrective Action**

Check the Number of Seed Modules Configuration in SETUP MODE with the actual number of modules connected

## ERROR CODE E20

Too Few Shaft Modules are connected to the System.

### **Probable Cause**

1. Number of Fan, Shaft, or Pressure Sensors Configuration is incorrect.
2. Ground Speed input Source is set incorrectly to d2.
3. Implement Harness not connected to Shaft Speed Module
4. Harnessing cut and/or pinched
5. Defective Module

### **Corrective Action**

1. Check the Number of Fan, Shaft, and Pressure Sensor Configuration in SETUP MODE with the actual number of sensors connected
2. Check the Ground Speed Sensor Configuration in SETUP MODE with the actual ground speed sensor connected
3. Check harness connection before and after the Shaft Speed Module.
4. Locate the fault and repair wires by splicing, soldering, and sealing wires.
5. Contact DICKEY-john Technical Support. See inside, back cover of this manual for phone number.

## ERROR CODE E21

Too Many Shaft Modules are connected to the System

### **Probable Cause**

System Contains incorrect parts (multiple Shaft Modules)

### **Corrective Action**

Disconnect any additional Modules that are connected. Disconnect one module at a time to determine which module is incorrect.

## ERROR CODE E30 X

Too Few Seed Sensors are connected to Module X (X is the number of the module, and Modules are numbered from the far Left side of the implement to the far Right side of the implement).

### Probable Cause

1. Failed Seed Sensors
2. Number of Seed Sensors for Module X Configuration is Incorrect.
3. Seed Sensors not connected sequentially
4. Implement Harness is not connected to all Seed Sensors.
5. Harnessing cut and/or pinched

### Corrective Action

1. Contact DICKEY-john Technical Support for a replacement sensor. See inside, back cover of this manual for phone number.
2. Check the Number of Seed Sensors for Module X Configuration in SETUP MODE with the actual number of Seed Sensors connected.
3. Seed Sensors on each module must be connected from the lowest to highest row inputs without skipping rows.
4. Check harness connection to sensor number that corresponds with the number in the lower display.
5. Locate the fault and repair wires by splicing, soldering, and sealing wires.

## ERROR CODE E31 X

Too Many Seed Sensors are connected to Module X (X is the number of the module, and Modules are numbered from the far Left side of the implement to the far Right side of the implement).

### Probable Cause

1. Number of Seed Sensors for Module X Configuration is Incorrect.
2. Implement Harness is connecting the Wrong Seed Sensors to Module X.

### Corrective Action

1. Check the Number of Seed Sensors for Module X Configuration in SETUP MODE with the actual number of Seed Sensors connected.
2. Check harness connection to sensor number that corresponds with the number in the lower display.

## ERROR CODE E40

Too Few Hopper Sensors are connected to the system

### Probable Cause

1. Number of Hopper Sensors Configuration is incorrect.
2. Hopper Sensors are Failed

3. Implement Harness is not Connected to all Hopper Sensors
4. Harnessing cut and/or pinched

### **Corrective Action**

1. Check the Number of Hopper Sensors Configuration in SETUP MODE with the actual number of Hopper Sensors connected.
2. Contact DICKEY-john Technical Support for a replacement sensor. See inside, back cover of this manual for phone number.
3. Check harness connection to sensor number that corresponds with the number in the lower display.
4. Locate the fault and repair wires by splicing, soldering, and sealing wires.

## **ERROR CODE E41**

Too Many Hopper Sensors are connected to the system.

### **Probable Cause**

Number of Hopper Sensors Configuration is incorrect

### **Corrective Action**

Check the Number of Hopper Sensors Configuration in SETUP MODE with the actual number of Hopper Sensors connected.

## **ERROR CODE E50**

Too Few Pressure Sensors are connected to the system.

### **Probable Cause**

1. Number of Pressure Sensors Configuration is incorrect
2. Pressure Sensors are failed
3. Implement Harness is not connected to all Pressure sensors
4. Harnessing cut and/or pinched

### **Corrective Action**

1. Check the Number of Pressure Sensors Configuration in SETUP MODE with the actual number of Pressure Sensors connected.
2. Contact DICKEY-john Technical Support for a replacement sensor. See inside, back cover of this manual for phone number.
3. Check harness connection to sensor number that corresponds with the number in the lower display.
4. Locate the fault and repair wires by splicing, soldering, and sealing wires.

## ERROR CODE E51

Too Many Pressure Sensors are connected to the system

Probable Cause

Number of Pressure Sensors configuration is incorrect.

### **Corrective Action**

Check the Number of Pressure Sensors Configuration in SETUP MODE with the actual number of Pressure Sensors connected.

## ERROR CODE E70

Module Supply Voltage is too Low (Shorted to 5v or to Ground)

**Probable Cause**

1. Harnessing cut and/or pinched
2. Module is defective

### **Corrective Action**

1. Locate the fault and repair wires by splicing, soldering, and sealing wires.
2. Contact DICKEY-john Technical Support for a replacement module. See inside, back cover of this manual for phone number.

## ERROR CODE E71

Module Supply Voltage is too High (Shorted to 12v)

**Probable Cause**

1. Harnessing cut and/or pinched
2. Module is defective

### **Corrective Action**

1. Locate the fault and repair wires by splicing, soldering, and sealing wires.
2. Contact DICKEY-john Technical Support for a replacement module. See inside, back cover of this manual for phone number.

## ERROR CODE E98 – E99

Internal Console Error – Contact DICKEY-john Technical Support for further assistance. See inside, back cover of this manual for phone number.

## CONNECTOR PIN OUTS

### Console

Seed Manager SE Non RS-232 Version		Seed Manager SE RS-232 Version			
J1		J1		J2	
FUNCTION	PIN #	FUNCTION	PIN #	FUNCTION	PIN #
PROGRAM OUT 1	aa	PROGRAM OUT 1	aa	TxD	11
PROGRAM OUT 2	bb	PROGRAM OUT 2	bb	RxD	12
RS-485A	A	RS-485 A	A	DTR	13
RS-485B	B	RS-485 B	B	DSR	14
+12VDC SW OUT-MODULE	1	+12 VDC SW OUT-MODULE	1	GND	15
GND-MODULE	2	GND-MODULE	2		
+12VDC SW OUT-AUX	V	+12 VDC SW OUT-AUX	V		
GND-AUX	W	GND-AUX	W		
AUX SENSOR SIGNAL	ff	AUX SENSOR SIGNAL	ff		
+V BATTERY	3	+V BATTERY	3		
GND BATTERY	4	GND BATTERY	4		

### MODULES

	Gray Connector		Black Connector	
	PIN	FUNCTION	PIN (B)	FUNCTION
<b>Material Flow Module 12 Row</b>	1	Sensor 1 Signal	1	Program line in
	2	Sensor 2 Signal	2	Program line out
	3	Sensor 3 Signal	3	RS-485 A in/out
	4	Sensor 4 Signal	4	RS-485 B in/out
	5	Sensor 5 Signal	5	Hopper Level 1
	6	Sensor 6 Signal	6	Hopper Level 2
	7	Sensor 7 Signal	7	Not Used
	8	Sensor 8 Signal	8	Not Used
	9	Sensor 9 Signal	9	Sensor 8VDC out
	10	Sensor 10 Signal	10	Sensor ground
	11	Sensor 11 Signal	11	Module 12VDC in
	12	Sensor 12 Signal	12	Module ground
<b>Material Flow Module 16 Row</b>	1	Sensor 1 Signal	1	Program line in
	2	Sensor 2 Signal	2	Program line out
	3	Sensor 3 Signal	3	RS-485 A in/out
	4	Sensor 4 Signal	4	RS-485 B in/out
	5	Sensor 5 Signal	5	Sensor 13 signal
	6	Sensor 6 Signal	6	Sensor 14 signal
	7	Sensor 7 Signal	7	Sensor 15 signal
	8	Sensor 8 Signal	8	Sensor 16 signal
	9	Sensor 9 Signal	9	Sensor 8VDC out
	10	Sensor 10 Signal	10	Sensor ground
	11	Sensor 11 Signal	11	Module 12VDC in
	12	Sensor 12 Signal	12	Module ground
<b>Shaft Monitor Module</b>	1	Ground Speed	1	Program line in
	2	Shaft Speed 1	2	Program line out
	3	Shaft Speed 2	3	RS-485 A
	4	Shaft Speed 3	4	RS-485 B
	5	Pressure 1	5	Fan Speed 1
	6	Pressure 2	6	Fan Speed 2
	7	Hopper Level 1	7	Not Used
	8	Hopper Level 2	8	Not Used
	9	Hopper Level 3	9	Sensor 8 VDC out
	10	Lift Switch-NC	10	Sensor ground
	11	Lift Switch-NO	11	Module 12VDC in
	12	Not Used	12	Module ground



## SETUP RECORD SHEET

Parameter Name
Population Hi Limit
Population Lo Limit
Row Width
Implement Width
Ground Speed Source
Distance Calibration
Split Row Configuration
Number of Seed Modules
Number of Seed Sensors Module 1
Number of Seed Sensors Module 2
Number of Seed Sensors Module 3
Number of Seed Sensors Module 4
Number of Seed Sensors Module 5
Number of Seed Sensors Module 6
Row Status
Total Number of Rows Configured
Number of Fan Speed Sensors
Fan Speed Sensor 1 Constant
Fan Speed Sensor 1 Hi Limit
Fan Speed Sensor 1 Lo Limit
Fan Speed Sensor 2 Constant
Fan Speed Sensor 2 Hi Limit
Fan Speed Sensor 2 Lo Limit
Number of Shaft Speed Sensors
Shaft Speed Sensor 1 Constant
Shaft Speed Sensor 1 Hi Limit
Shaft Speed Sensor 1 Lo Limit
Shaft Speed Sensor 2 Constant
Shaft Speed Sensor 2 Hi Limit
Shaft Speed Sensor 2 Lo Limit
Shaft Speed Sensor 3 Constant
Shaft Speed Sensor 3 Hi Limit
Shaft Speed Sensor 3 Lo Limit
Number of Hopper Sensors
Number of Pressure Sensors
Pressure Sensor 1 Hi Limit
Pressure Sensor 1 Lo Limit
Pressure Sensor 2 Hi Limit
Pressure Sensor 2 Lo Limit
Blockage Mode Configuration
Population Filter
Population Scaling

## SETUP RECORD SHEET

Parameter Name
Population Hi Limit
Population Lo Limit
Row Width
Implement Width
Ground Speed Source
Distance Calibration
Split Row Configuration
Number of Seed Modules
Number of Seed Sensors Module 1
Number of Seed Sensors Module 2
Number of Seed Sensors Module 3
Number of Seed Sensors Module 4
Number of Seed Sensors Module 5
Number of Seed Sensors Module 6
Row Status
Total Number of Rows Configured
Number of Fan Speed Sensors
Fan Speed Sensor 1 Constant
Fan Speed Sensor 1 Hi Limit
Fan Speed Sensor 1 Lo Limit
Fan Speed Sensor 2 Constant
Fan Speed Sensor 2 Hi Limit
Fan Speed Sensor 2 Lo Limit
Number of Shaft Speed Sensors
Shaft Speed Sensor 1 Constant
Shaft Speed Sensor 1 Hi Limit
Shaft Speed Sensor 1 Lo Limit
Shaft Speed Sensor 2 Constant
Shaft Speed Sensor 2 Hi Limit
Shaft Speed Sensor 2 Lo Limit
Shaft Speed Sensor 3 Constant
Shaft Speed Sensor 3 Hi Limit
Shaft Speed Sensor 3 Lo Limit
Number of Hopper Sensors
Number of Pressure Sensors
Pressure Sensor 1 Hi Limit
Pressure Sensor 1 Lo Limit
Pressure Sensor 2 Hi Limit
Pressure Sensor 2 Lo Limit
Blockage Mode Configuration
Population Filter
Population Scaling

*Dealers have the responsibility of calling to the attention of their customers the following warranty prior to acceptance of an order from their customer for any DICKY-john product.*

## **DICKY-john<sup>®</sup> WARRANTY**

DICKY-john warrants to the original purchaser for use that, if any part of the product proves to be defective in material or workmanship within one year from date of original installation, and is returned to DICKY-john within 30 days after such defect is discovered, DICKY-john will (at our option) either replace or repair said part. This warranty does not apply to damage resulting from misuse, neglect, accident, or improper installation or maintenance. Said part will not be considered defective if it substantially fulfills the performance expectations. THE FOREGOING WARRANTY IS EXCLUSIVE AND IN LIEU OF ALL OTHER WARRANTIES OF MERCHANTABILITY, FITNESS FOR PURPOSE, AND OF ANY OTHER TYPE, WHETHER EXPRESS OR IMPLIED. DICKY-john neither assumes nor authorizes anyone to assume for it any other obligation or liability in connection with said part and will not be liable for consequential damages. Purchaser accepts these terms and warranty limitations unless the product is returned within fifteen days for full refund of purchase price.

**For DICKY-john Service Department,  
call 1-800-637-3302 in either the U.S.A. or Canada**



*Revolutionizing Electronics*

**Headquarters:**

5200 Dickey-john Road, Auburn, IL 62615

TEL: 217-438-3371, FAX: 217-438-6012, WEB: [www.dickey-john.com](http://www.dickey-john.com)

**Europe:**

DICKY-john Europe S.A., 165, boulevard de Valmy, 92706 - Colombes - France

TEL: 33 (0) 1 41 19 21 80, FAX: 33 (0) 1 47 86 00 07

